

DSC-T5

SERVICE MANUAL

LEVEL 2

Ver 1.2 2005.10

Revision History

How to use
Acrobat Reader

Internal memory
ON BOARD



Photo: Silver

US Model
Canadian Model
AEP Model
UK Model
E Model
Australian Model
Hong Kong Model
Chinese Model
Korea Model
Brazilian Model
Japanese Model
Tourist Model

Link

SPECIFICATIONS	BLOCK DIAGRAMS	PRINTED WIRING BOARDS
SERVICE NOTE	FRAME SCHEMATIC DIAGRAMS	REPAIR PARTS LIST
DISASSEMBLY	SCHEMATIC DIAGRAMS	

• Precaution on Replacing the SY-134 Board

The components identified by mark \triangle or dotted line with mark \triangle are critical for safety. Replace only with part number specified.

Les composants identifiés par une marque \triangle sont critiques pour la sécurité. Ne les remplacer que par une pièce portant le numéro spécifié.

DIGITAL STILL CAMERA

SONY[®]



Cyber-shot



SPECIFICATIONS

Camera

[System]

Image device	7.17 mm (1/2.5 type) color CCD, Primary color filter
Total pixel number of camera	Approx. 5 255 000 pixels
Effective pixel number of camera	Approx. 5 090 000 pixels
Lens	Carl Zeiss Vario-Tessar 3× zoom lens f = 6.33 – 19.0 mm (38 – 114 mm when converted to a 35 mm still camera) F3.5 – 4.4
Exposure control	Automatic exposure, Scene Selection (10 modes)
White balance	Automatic, Daylight, Cloudy, Fluorescent, Incandescent, Flash
File format (DCF compliant)	Still images: Exif Ver. 2.2 JPEG compliant, DPOF compatible Movies: MPEG1 compliant (Monaural)
Recording media	Internal Memory (32 MB) “Memory Stick Duo”
Flash	Recommended distance (ISO set to Auto): approx. 0.1 m to 2.5 m (3 15/16 inches to 8 feet 2 7/16 inches) (W)/approx. 0.5 m to 2.0 m (1 feet 7 11/16 inches to 6 feet 6 3/4 inches) (T)

[Input and Output connectors]

Multi connector	
USB communication	Hi-Speed USB (USB 2.0 compliant)

[LCD screen]

LCD panel	6.2 cm (2.5 type) TFT drive
Total number of dots	230 400 (960×240) dots

[Power, general]

Power	Rechargeable battery pack NP-FT1, 3.6 V AC-LS5K AC Adaptor (not supplied), 4.2 V
Power consumption (during shooting)	1.1 W
Operating temperature	0°C to +40°C (+32°F to +104°F)
Storage temperature	–20°C to +60°C (–4°F to +140°F)
Dimensions	93.6×60.0×20.3 mm (3 3/4×2 3/8×13/16 inches) (W/H/D, excluding protrusions)
Mass	Approx. 139 g (4.9 oz) (including NP-FT1 battery pack and wrist strap, etc.)
Microphone	Electret condenser microphone
Speaker	Dynamic speaker
Exif Print	Compatible
PRINT Image Matching III	Compatible
PictBridge	Compatible

BC-CS3 battery charger

Power requirements	AC 100 to 240 V, 50/60 Hz, 3.2 W
Output voltage	DC 4.2 V, 500 mA
Operating temperature	0°C to +40°C (+32°F to +104°F)
Storage temperature	–20°C to +60°C (–4°F to +140°F)
Dimensions	Approx. 66×23×91 mm (2 5/8×29/32×3 5/8 inches) (W/H/D)
Mass	Approx. 70 g (2.7 oz)

Rechargeable battery pack NP-FT1

Used battery	Lithium-ion battery
Maximum voltage	DC 4.2 V
Nominal voltage	DC 3.6 V
Capacity	2.4 Wh (680 mAh)

Design and specifications are subject to change without notice.

CAUTION

Danger of explosion if battery is incorrectly replaced.
Replace only with the same or equivalent type.

SAFETY-RELATED COMPONENT WARNING!!

COMPONENTS IDENTIFIED BY MARK \triangle OR DOTTED LINE WITH MARK \triangle ON THE SCHEMATIC DIAGRAMS AND IN THE PARTS LIST ARE CRITICAL TO SAFE OPERATION. REPLACE THESE COMPONENTS WITH SONY PARTS WHOSE PART NUMBERS APPEAR AS SHOWN IN THIS MANUAL OR IN SUPPLEMENTS PUBLISHED BY SONY.

ATTENTION AU COMPOSANT AYANT RAPPORT À LA SÉCURITÉ!

LES COMPOSANTS IDENTIFIÉS PAR UNE MARQUE \triangle SUR LES DIAGRAMMES SCHÉMATIQUES ET LA LISTE DES PIÈCES SONT CRITIQUES POUR LA SÉCURITÉ DE FONCTIONNEMENT. NE REMPLACER CES COMPOSANTS QUE PAR DES PIÈCES SONY DONT LES NUMÉROS SONT DONNÉS DANS CE MANUEL OU DANS LES SUPPLÉMENTS PUBLIÉS PAR SONY.

SAFETY CHECK-OUT

After correcting the original service problem, perform the following safety checks before releasing the set to the customer.

1. Check the area of your repair for unsoldered or poorly-soldered connections. Check the entire board surface for solder splashes and bridges.
2. Check the interboard wiring to ensure that no wires are "pinched" or contact high-wattage resistors.
3. Look for unauthorized replacement parts, particularly transistors, that were installed during a previous repair. Point them out to the customer and recommend their replacement.
4. Look for parts which, through functioning, show obvious signs of deterioration. Point them out to the customer and recommend their replacement.
5. Check the B+ voltage to see it is at the values specified.
6. FLEXIBLE Circuit Board Repairing
 - Keep the temperature of the soldering iron around 270°C during repairing.
 - Do not touch the soldering iron on the same conductor of the circuit board (within 3 times).
 - Be careful not to apply force on the conductor when soldering or unsoldering.

Unleaded solder

Boards requiring use of unleaded solder are printed with the lead-free mark (LF) indicating the solder contains no lead. (Caution: Some printed circuit boards may not come printed with the lead free mark due to their particular size.)



: LEAD FREE MARK

Unleaded solder has the following characteristics.

- Unleaded solder melts at a temperature about 40°C higher than ordinary solder.
Ordinary soldering irons can be used but the iron tip has to be applied to the solder joint for a slightly longer time.
Soldering irons using a temperature regulator should be set to about 350°C.
Caution: The printed pattern (copper foil) may peel away if the heated tip is applied for too long, so be careful!
- Strong viscosity
Unleaded solder is more viscous (sticky, less prone to flow) than ordinary solder so use caution not to let solder bridges occur such as on IC pins, etc.
- Usable with ordinary solder
It is best to use only unleaded solder but unleaded solder may also be added to ordinary solder.

TABLE OF CONTENTS

<i>Section</i>	<i>Title</i>	<i>Page</i>
1. SERVICE NOTE		
1-1.	Description on Self-diagnosis Display	1-1
1-2.	Process After Fixing Flash Error	1-1
1-3.	Method for Copying or Erasing the Data in Internal Memory	1-2
1-4.	Precaution on Replacing the SY-134 Board	1-3
2. DISASSEMBLY		
2-1.	Disassembly	2-3
3. BLOCK DIAGRAMS		
3-1.	Overall Block Diagram (1/2)	3-1
3-2.	Overall Block Diagram (2/2)	3-3
3-3.	Power Block Diagram	3-5
4. PRINTED WIRING BOARDS AND SCHEMATIC DIAGRAMS		
4-1.	Frame Schematic Diagram	4-1
4-2.	Schematic Diagrams	4-5
4-3.	Printed Wiring Boards	4-31
4-4.	Waveforms	4-45
4-5.	Mounted Parts Location	4-48
5. REPAIR PARTS LIST		
5-1.	Exploded Views	5-2
5-2.	Electrical Parts List	5-5

1. SERVICE NOTE

1-1. DESCRIPTION ON SELF-DIAGNOSIS DISPLAY

Self-diagnosis display

The camera has a self-diagnosis display. This function displays the camera condition with five-digits (a combination of a letter and figures) on the LCD screen. If this occurs check the following code chart. The five-digits display informs you of the camera's current condition. The last two digits (indicated by □□) will differ depending on the state of the camera.

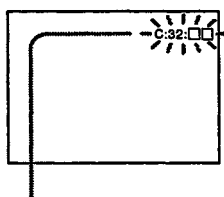

Self-diagnosis display

- C: □□: □□

You can reverse the camera malfunction yourself. (However, contact your Sony dealer or local authorized Sony service facility when you cannot recover from the camera malfunction.)

- E: □□: □□

Contact your Sony dealer or local authorized Sony service facility.

Display Code	Countermeasure	Cause	Caution Display During Error
C:32:□□	Turn the power off and on again.	Trouble with hardware.	SYSTEM ERROR
C:13:□□	Format the "Memory Stick" or internal memory.	"Memory Stick" or internal memory is unformatted.	FORMAT ERROR
	Insert a new "Memory Stick".	"Memory Stick" is broken.	MEMORY STICK ERROR
	Turn the power off and on again.	Trouble with internal memory.	INTERNAL MEMORY ERROR
E:61:□□	Checking of lens drive circuit.	When failed in the focus and zoom initialization.	—
E:91:□□	Checking of flash unit or replacement of flash unit. (Note)	Abnormality when flash is being charged.	

Note: After repair, be sure to perform "1-2. PROCESS AFTER FIXING FLASH ERROR".

1-2. PROCESS AFTER FIXING FLASH ERROR

When "FLASH error" (Self-diagnosis Code E : 91 : **) occurs, to prevent any abnormal situation caused by high voltage, setting of the flash is changed automatically to disabling charge and flash setting.

After fixing, this setting needs to be deactivated. Flash error code can be initialized by the operations on the Setup screen.

Method for Initializing the Flash Error Code

Initialize

Initializes the setting to the default setting.

<input type="checkbox"/>	OK	See the following procedure.
<input checked="" type="checkbox"/>	Cancel	Cancels the resetting.

- ① Select [OK] with ▲ on the control button, then press ●.
The message "Initialize all settings Ready?" appears.
 - ② Select [OK] with ▲, then press ●.
The settings are reset to the default setting.
- Make sure that the power is not disconnected during resetting.

1-3. METHOD FOR COPYING OR ERASING THE DATA IN INTERNAL MEMORY

The data can be copied/erased by the operations on the Setup screen. (When erasing the data, execute formatting the internal memory.)

Note: 1 When replacing the SY-134 board, erase the data in internal memory of the board before replacement.

Note: 2 When replacing the SY-134 board or the IC401 on the SY-134 board, execute formatting and initialize the internal memory after replacement.

Method for Copying the Data in Internal Memory



Copy

Copies all images in the internal memory to a "Memory Stick Duo".

<input type="checkbox"/>	OK	See the following procedure.
<input checked="" type="checkbox"/>	Cancel	Cancels the copying.

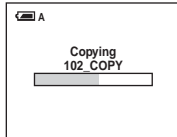
- ① Insert a "Memory Stick Duo" having 32 MB or larger capacity.
- ② Select [OK] with ▲ on the control button, then press ●.
The message "All data in internal memory will be copied Ready?" appears.
- ③ Select [OK] with ▲, then press ●.
Copying starts.



- Use a fully charged battery pack or the AC Adaptor (not supplied). If you attempt to copy image files using a battery pack with little remaining charge, the battery pack may run out, causing copying to fail or possibly corrupting the data.
- You cannot copy individual images.
- The original images in the internal memory are retained even after copying. To delete the contents of the internal memory, remove the "Memory Stick Duo" after copying, then execute the [Format] command in  (Internal Memory Tool).
- You cannot select a folder copied on a "Memory Stick Duo".
- Even if you copy data, a  (Print order) mark is not copied.

Method for Formatting the Internal Memory

Format

Formats the internal memory.

- Note that formatting irrevocably erases all data in the internal memory, including even protected images.

<input type="checkbox"/>	OK	See the following procedure.
<input checked="" type="checkbox"/>	Cancel	Cancels the formatting.

- ① Select [OK] with ▲ on the control button, then press ●.
The message "All data in internal memory will be erased Ready?" appears.
- ② Select [OK] with ▲, then press ●.
The format is complete.

1-4. PRECAUTION ON REPLACING THE SY-134 BOARD

VIDEO OUT Default Data Check

When you replace to the repairing board, the written data of repairing board also might be changed to original setting because of broadcast system (NTSC/PAL).

When the data has changed because of board replacing etc, check the default data of VIDEO OUT if destination code is right. If not, rewrite to the right value.

VIDEO OUT Default Data

Page	Address	Data	
		NTSC	PAL
4F	8D	00	01
4F	A2	00	01

Writing Method:

- 1) Select page: 00, address: 01 and set data: 01.
- 2) Select page: 4F, address: 8D, and set data: 00 (NTSC) or data: 01 (PAL).
- 3) Select page: 4F, address: A2, and set data: 00 (NTSC) or data: 01 (PAL).
- 4) Select page: 40, address: 38, and set data: 00.
- 5) Click **[Save]** on the SEUS screen.
- 6) Select page: 80, address: 34, and check that the data is "00".
- 7) Select page: 80, address: 30, and check that the data is "00".
- 8) Select page: 00, address: 01, and set data: 00.

Initial Language Data Check

If the SY-134 board was replaced, initial language setting may be changed. Accordingly, change the following data so as to set same initial language as that of the set distributing in each region.

Initial language: Language displayed at the next starting if the setting of Setup menu was reset.

It is different from the language setting selectable with the menu.

Initial Language Data

Page	Address	Data	Language	GP1	GP2	GP3	GP4
4F	8C	00	English		●	●	●
		01	Japanese	●			
		04	Spanish			●	●
		06	Portugal				●
		08	Simplified Chinese				●
		0B	Russian			●	
		0D	Korean				●

Note: GP1 is fixed to Japanese.

GP2 is fixed to English.

GP3 is either English, Spanish, or Russian.

GP4 is either English, Spanish, Portugal, Simplified Chinese, or Korean.

Writing Method:

- 1) Select page: 00, address: 01 and set data: 01.
- 2) Select page: 4F, address: 8C, and set the Initial Language Data.
- 3) Select page: 40, address: 38, and set data: 00.
- 4) Click **[Save]** on the SEUS screen.
- 5) Select page: 80, address: 34, and check that the data is "00".
- 6) Select page: 80, address: 30, and check that the data is "00".
- 7) Select page: 00, address: 01, and set data: 00.
- 8) Turn off the camera.
- 9) Turn on the camera. Execute "Initialize" of Setup screen.
- 10) Check the language displayed when the camera starts.

2. DISSASSEMBLY

NOTE FOR REPAIR

- Make sure that the flat cable and flexible board are not cracked or bent at the terminal. Do not insert the cable insufficiently nor crookedly.
- When remove a connector, dont' pull at wire of connector. It is possible that a wire is snapped.
- When installing a connector, dont' press down at wire of connector. It is possible that a wire is snapped.
- Do not apply excessive load to the gilded flexible board.

Cut and remove the part of gilt which comes off at the point. (Be careful or some pieces of gilt may be left inside)

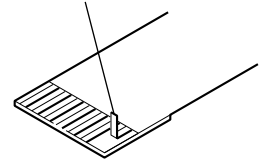

DISCHARGING OF THE ST-126 BOARD'S CHARGING CAPACITOR (C005)

The charging capacitor (C005) of the ST-126 board is charged up to the maximum 300 V potential. There is a danger of electric shock by this high voltage when the capacitor is handled by hand. The electric shock is caused by the charged voltage which is kept without discharging when the main power of the unit is simply turned off. Therefore, the remaining voltage must be discharged as described below.

Preparing the Short Jig

To preparing the short jig, a small clip is attached to each end of a resistor of 1 k Ω / 1 W (1-215-869-11). Wrap insulating tape fully around the leads of the resistor to prevent electrical shock.

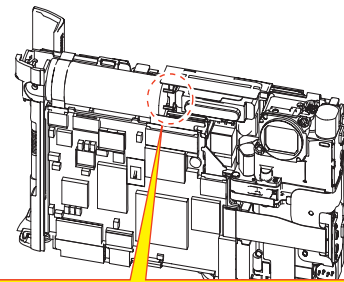
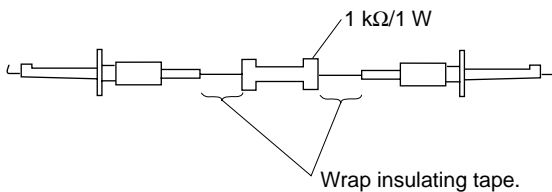

Note: High-voltage cautions

Discharging the Capacitor

Short-circuit between the two points with the short jig about 10 seconds.

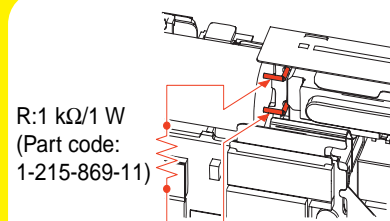

NOTE FOR INSTALLATION OF SPEAKER (SP901) AND SW-455 FLEXIBLE BOARD

Put the speaker (SP901) and SW-455 flexible board on a flat table when you solder. It is important that each back become the horizontal.

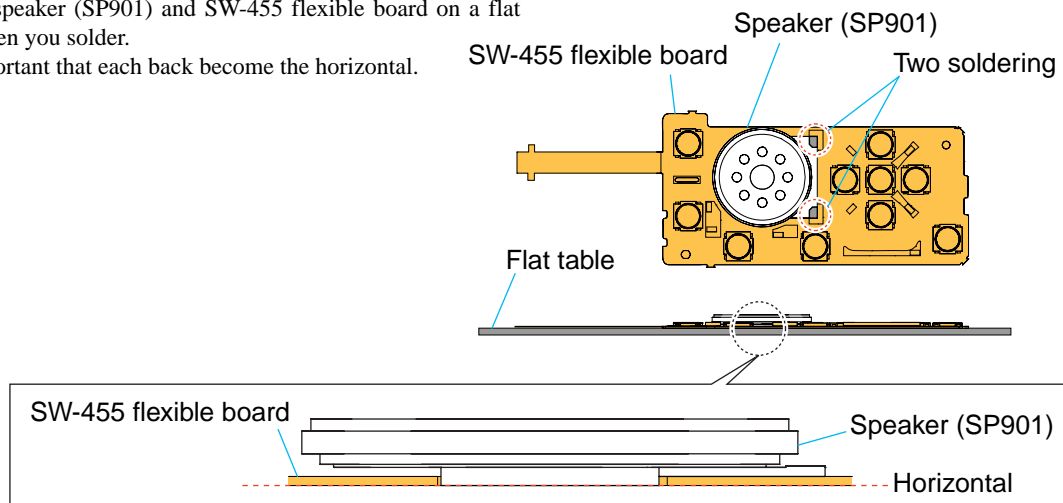

The following flow chart shows the disassembly procedure.

2-1. DISASSEMBLY

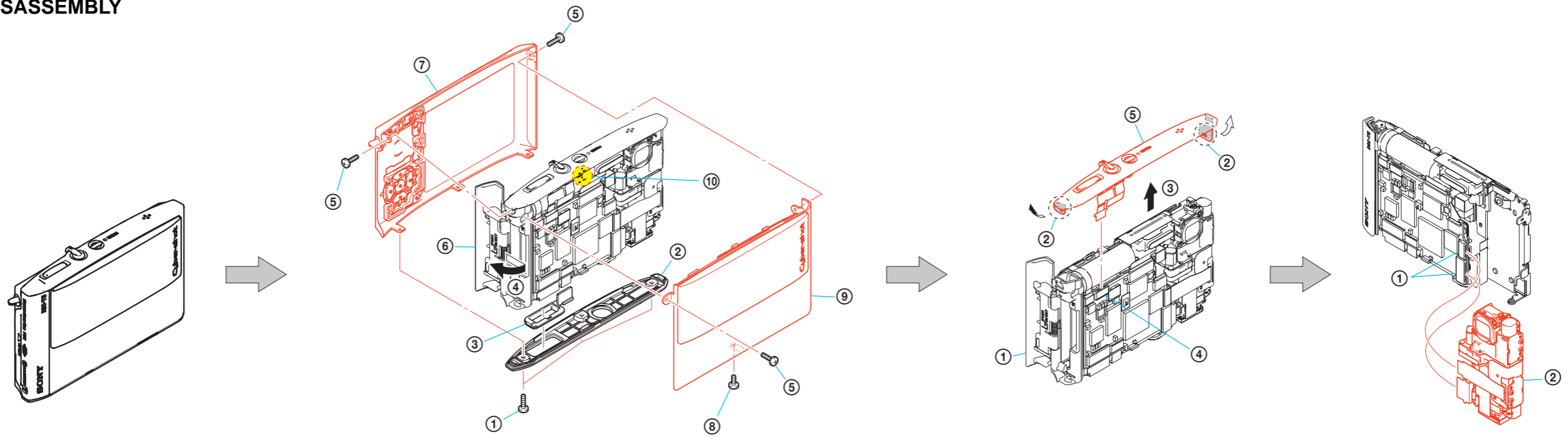

- ① Screw (M1.4) x3
- ② Cabinet bottom
- ③ Multi cover
- ④ Open the BT lid.
- ⑤ Screw (M1.4) x3
- ⑥ Close the BT lid.
- ⑦ Cabinet (rear) block

- ⑧ Screw (M1.4) x1
- ⑨ Cabinet (front) assembly
- ⑩ Discharging the Capacitor.

Refer to page 2-1 "Discharging of the ST-126 board's charging capacitor (C005)", when discharging the capacitor.

- ① Open the BT lid.
- ② Claw x2
- ③ Rifting up the Control switch block.
- ④ Connector x1
- ⑤ Control switch block

- ① Connector x2
- ② Lens block assembly

How to disassemble BT lid

- ① Open the BT lid.
- ② Claw x2
- ③ BT lid **HELP**

The BT lid is not removed unless there is the rear cabinet. When removing the BT lid, the rear cabinet must be in the assembled state.

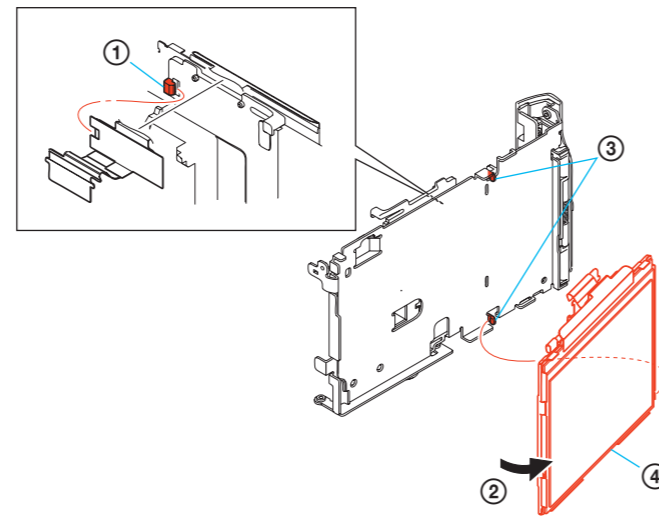

- ① Hook x1
- ② Remove the D901, LCD901.
- ③ Hook x2
- ④ D901, LCD901

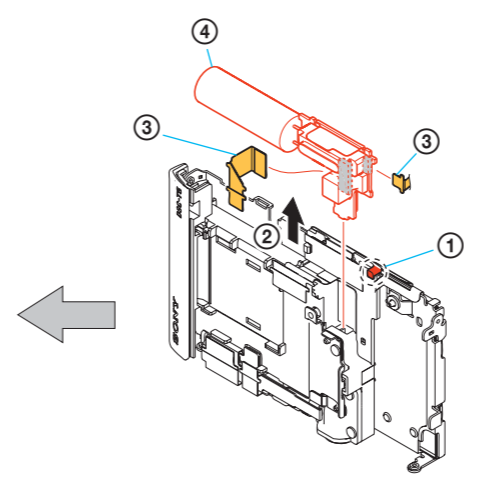

- ① Hook x1
- ② Rifting up the ST board.
- ③ Flexible board x2
- ④ ST board

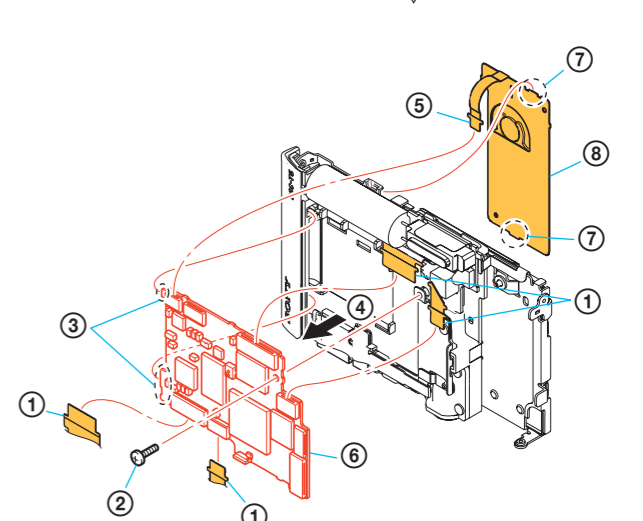

- ① Flexible board x4
- ② Screw (M1.7) x1
- ③ Boss x2
- ④ Remove the SY board.
- ⑤ Flexible board x1
- ⑥ SY board
- ⑦ Claw x2
- ⑧ SW board

Refer to page 2-1 "Note for installation of speaker (SP901) and SW-455 flexible board", when change the speaker (SP901)

HELP

Sheet attachment positions and procedures of processing the flexible boards/harnesses are shown.

BT lid

When mounting the BT lid, fit a BT hinge spring in a space between BT hinge plate and BT lid.

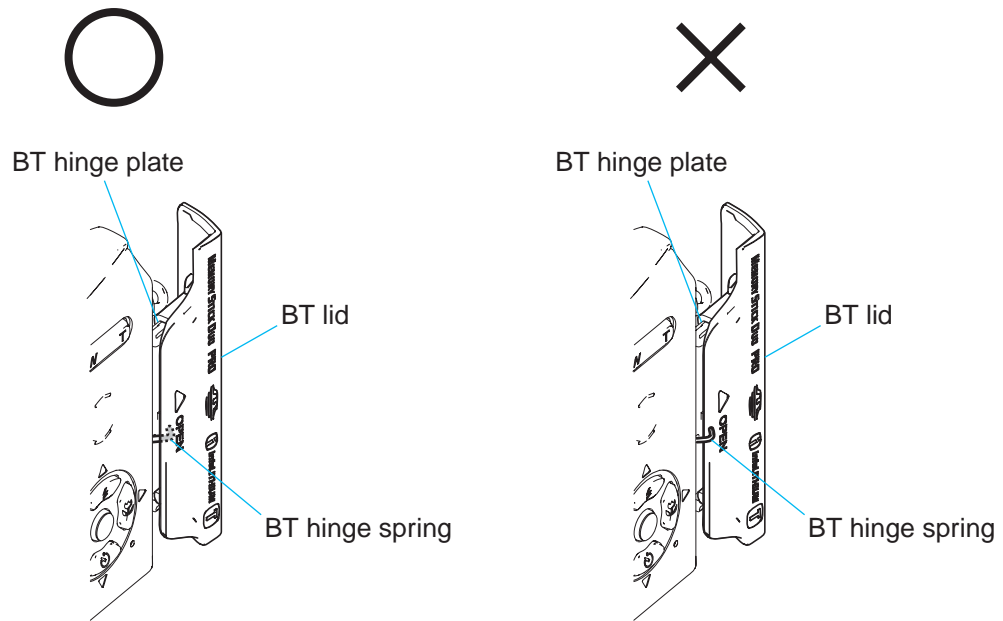

Sheet

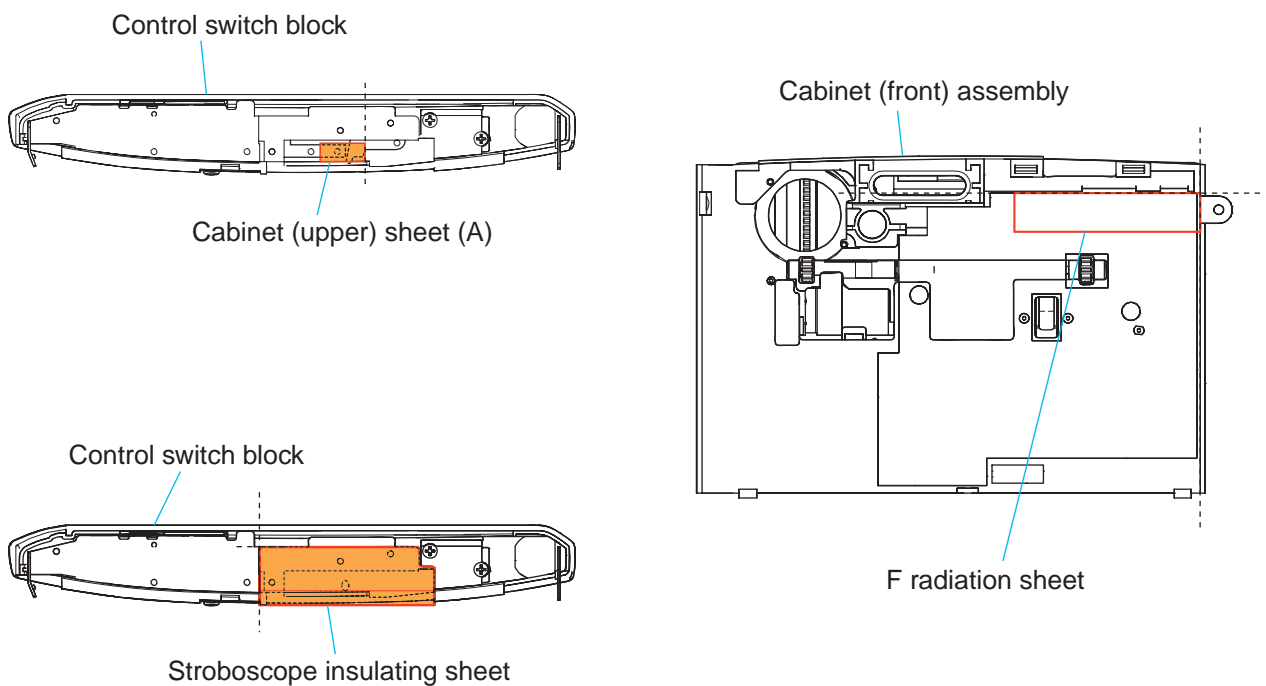

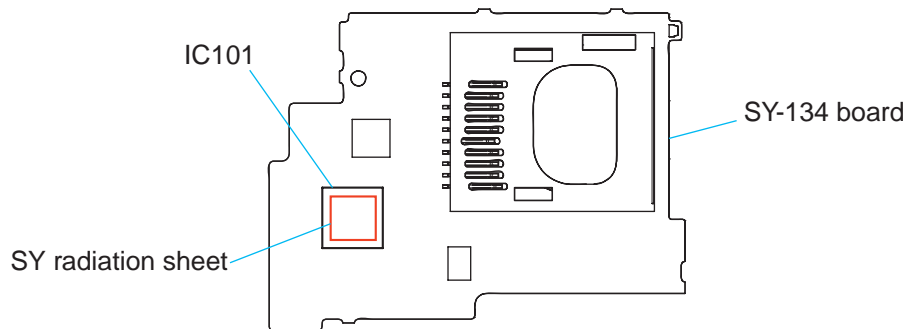
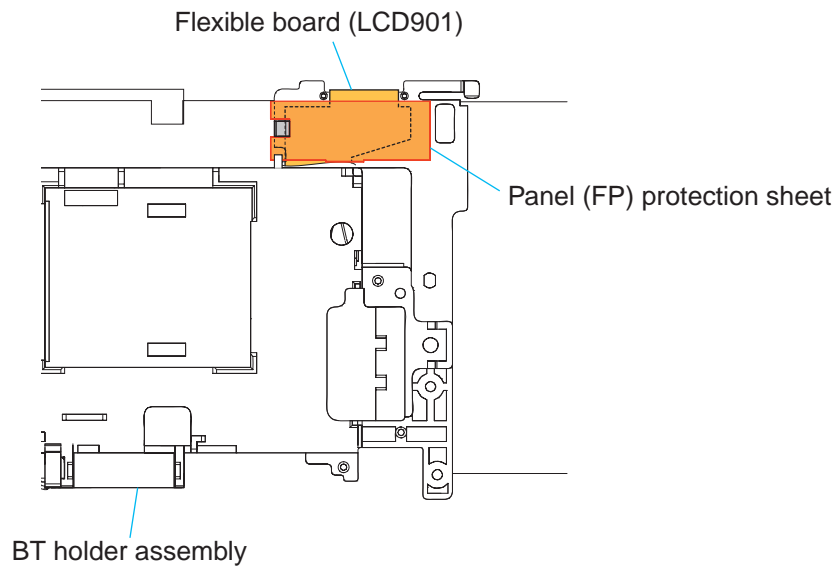

JK-292 flexible board

Install the JK-292 flexible board so that the lithium secondary battery is housed in a recess of the BT holder assembly.

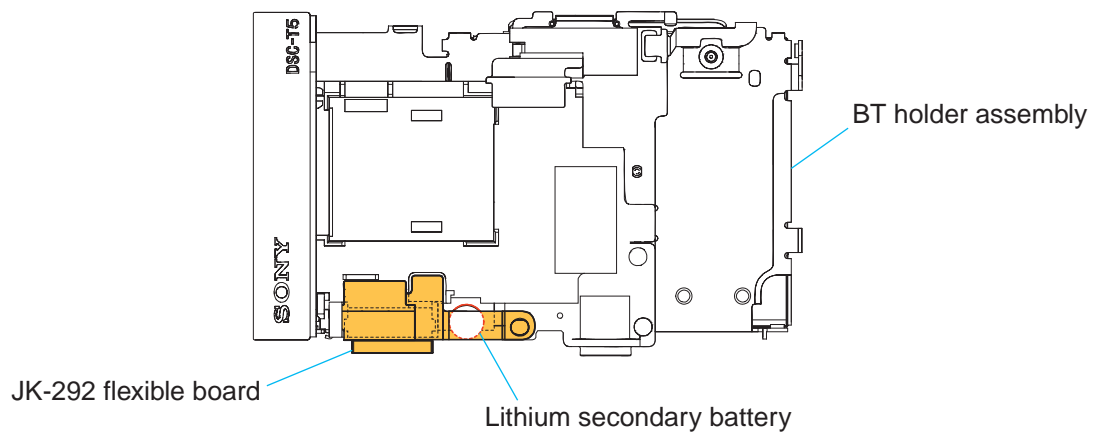

3. BLOCK DIAGRAMS

Link

• [OVERALL BLOCK DIAGRAM \(1/2\)](#)

• [POWER BLOCK DIAGRAM](#)

• [OVERALL BLOCK DIAGRAM \(2/2\)](#)

3. BLOCK DIAGRAMS

3-1. OVERALL BLOCK DIAGRAM (1/2) () : Number in parenthesis () indicates the division number of schematic diagram where the component is located.

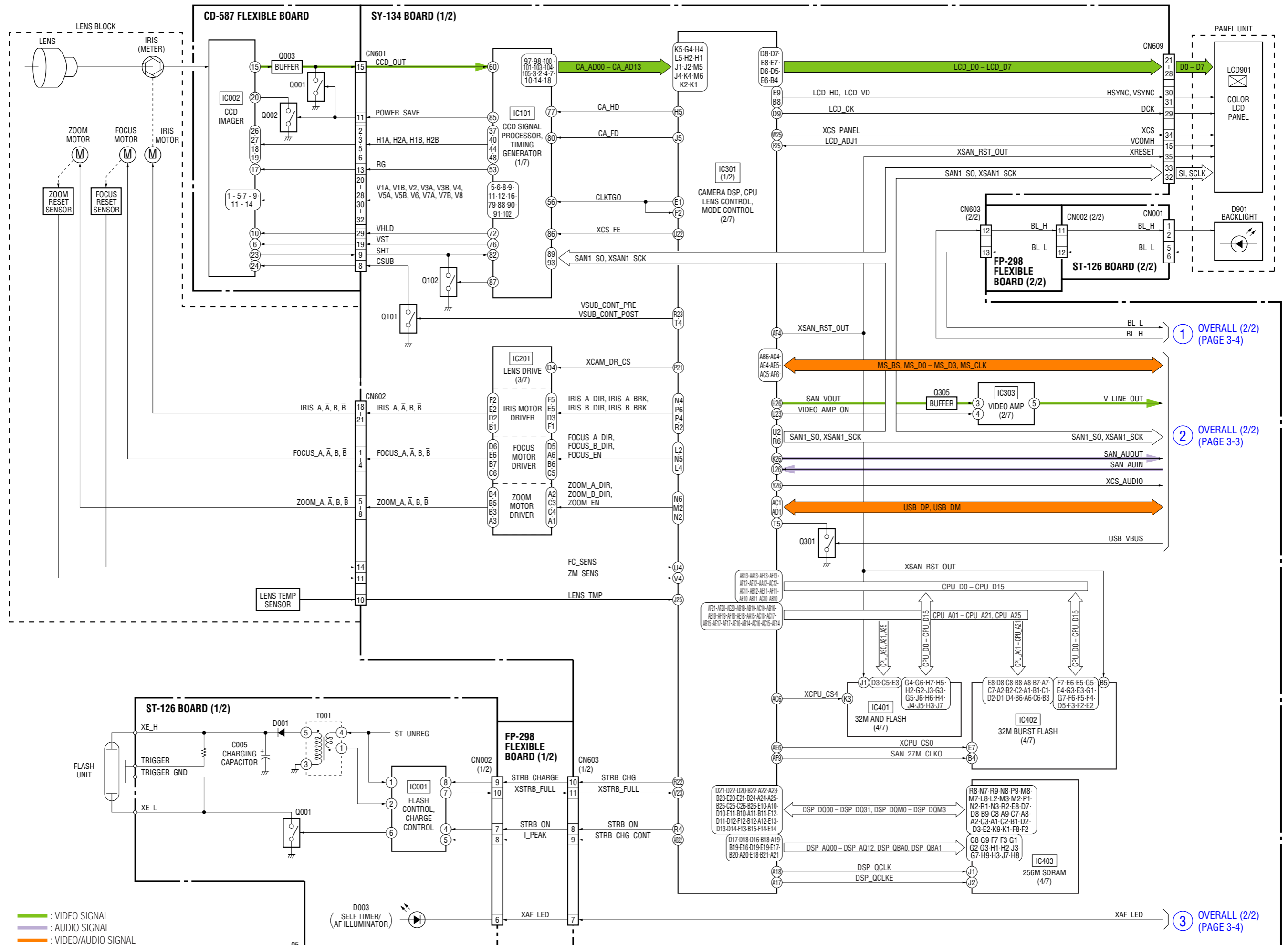

1 OVERALL (2/2)
PAGE 3-4

2 OVERALL (2/2)
PAGE 3-3

3 OVERALL (2/2)
PAGE 3-4

3-2. OVERALL BLOCK DIAGRAM (2/2) () : Number in parenthesis () indicates the division number of schematic diagram where the component is located.

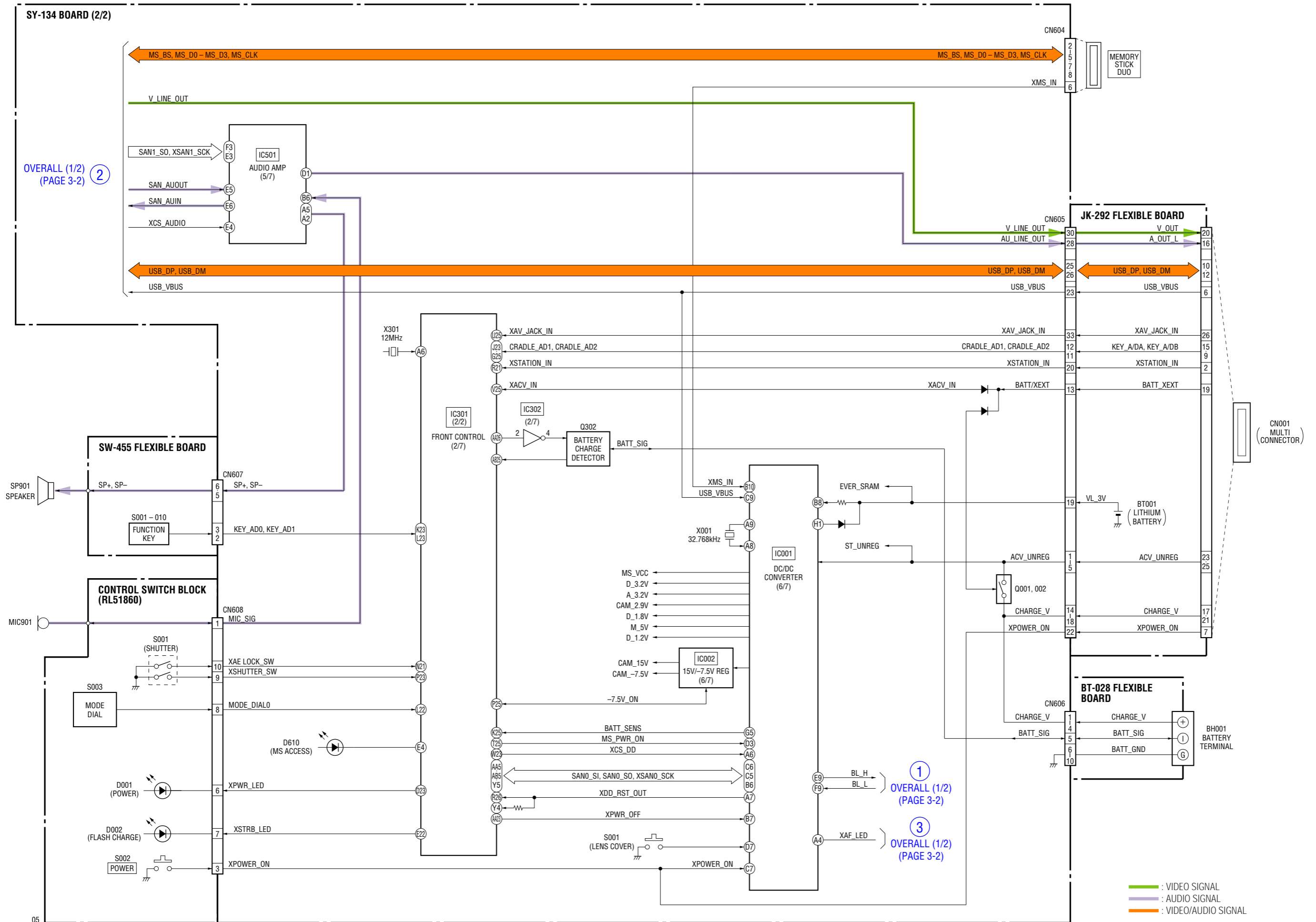

3-3. POWER BLOCK DIAGRAM () : Number in parenthesis () indicates the division number of schematic diagram where the component is located.

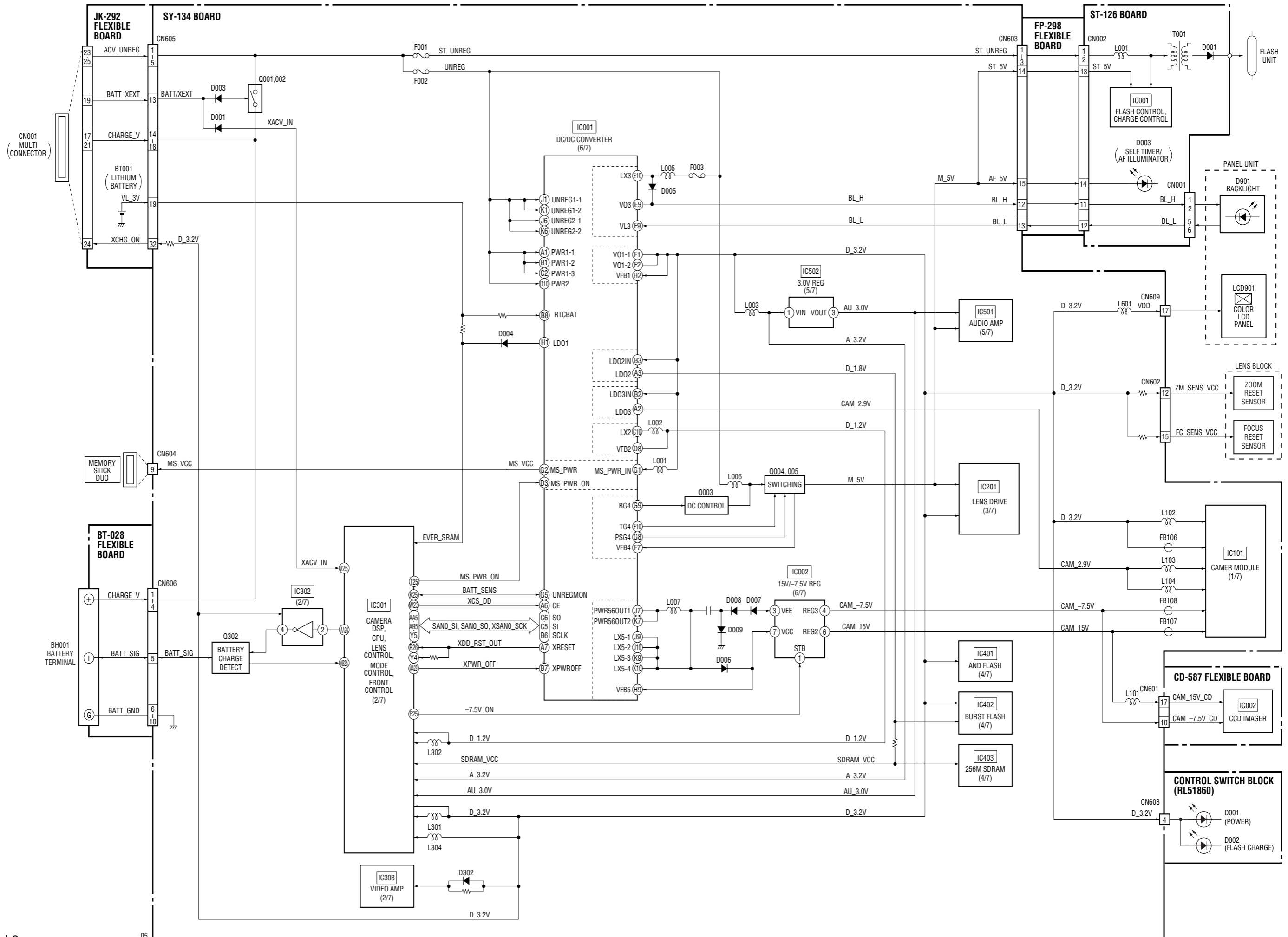

4. PRINTED WIRING BOARDS AND SCHEMATIC DIAGRAMS

4-1. FRAME SCHEMATIC DIAGRAM

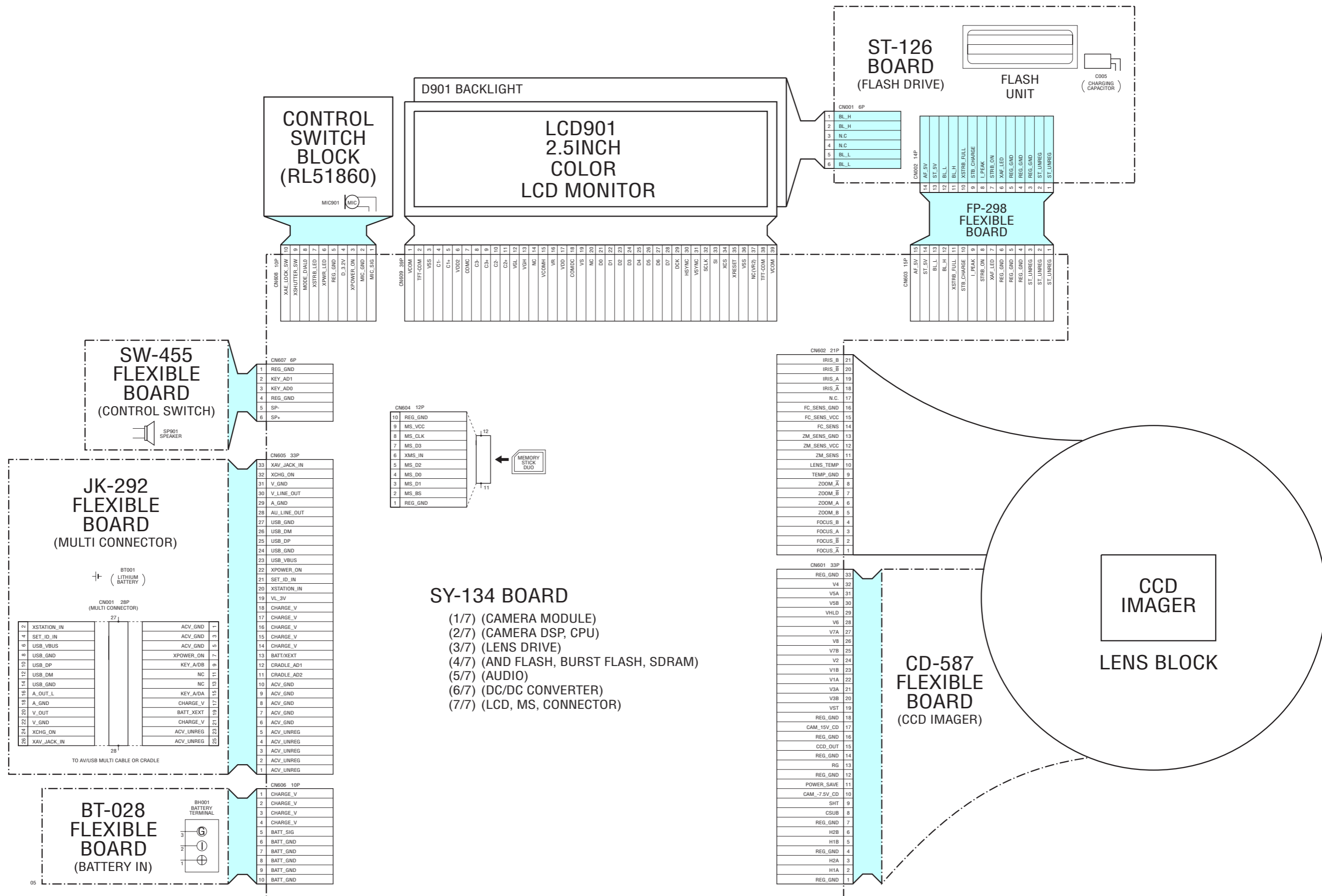

4-2. SCHEMATIC DIAGRAMS

Link

<ul style="list-style-type: none">• CD-587 FLEXIBLE BOARD (CCD IMAGER)	<ul style="list-style-type: none">• BT-028 FLEXIBLE BOARD (BATTERYIN)
<ul style="list-style-type: none">• ST-126 BOARD (FLASH DRIVE)	<ul style="list-style-type: none">• FP-298 FLEXIBLE BOARD (SY-ST CONNECTION BOARD)
<ul style="list-style-type: none">• JK-292 FLEXIBLE BOARD (MULTI CONNECTOR)	<ul style="list-style-type: none">• CONTROL SWITCH BLOCK (RL51860)
<ul style="list-style-type: none">• SW-455 FLEXIBLE BOARD (CONTROL SWITCH)	
<ul style="list-style-type: none">• COMMON NOTE FOR SCHEMATIC DIAGRAMS	<ul style="list-style-type: none">• WAVEFORMS

4-2. SCHEMATIC DIAGRAMS

4-2. SCHEMATIC DIAGRAMS

THIS NOTE IS COMMON FOR SCHEMATIC DIAGRAMS
(In addition to this, the necessary note is printed in each block)

(For schematic diagrams)

- All capacitors are in μF unless otherwise noted. $\text{pF} : \mu\text{F} : 50\text{V}$ or less are not indicated except for electrolytics and tantalums.
- Chip resistors are $1/10\text{W}$ unless otherwise noted. $\text{k}\Omega=1000\ \Omega$, $\text{M}\Omega=1000\ \text{k}\Omega$.
- Caution when replacing chip parts.
New parts must be attached after removal of chip.
Be careful not to heat the minus side of tantalum capacitor, Because it is damaged by the heat.
- Some chip part will be indicated as follows.

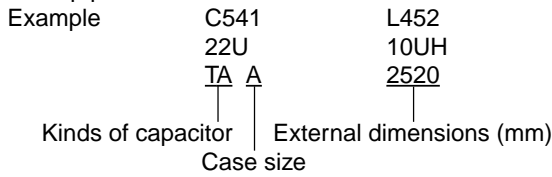

- Constants of resistors, capacitors, ICs and etc with XX indicate that they are not used.
In such cases, the unused circuits may be indicated.
- Parts with \star differ according to the model/destination. Refer to the mount table for each function.
- All variable and adjustable resistors have characteristic curve B, unless otherwise noted.
- Signal name
XEDIT \rightarrow $\overline{\text{EDIT}}$ PB/XREC \rightarrow $\overline{\text{PB/REC}}$
- : non flammable resistor
- : fusible resistor
- : panel designation
- : B+ Line
- : B- Line
- : IN/OUT direction of (+,-) B LINE.
- : adjustment for repair.
- : not use circuit
- Circled numbers refer to waveforms.

(Measuring conditions voltage and waveform)

- Voltages and waveforms are measured between the measurement points and ground when camera shoots color bar chart of pattern box. They are reference values and reference waveforms.
(VOM of DC $10\text{M}\Omega$ input impedance is used)
- Voltage values change depending upon input impedance of VOM used.)

Precautions for Replacement of Imager

- If the imager has been replaced, carry out all the adjustments for the camera section.
- As the imager may be damaged by static electricity from its structure, handle it carefully like for the MOS IC.
In addition, ensure that the receiver is not covered with dusts nor exposed to strong light.

1. Connection

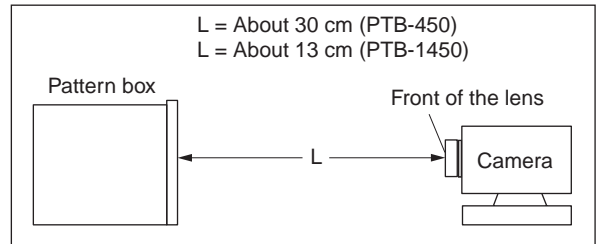
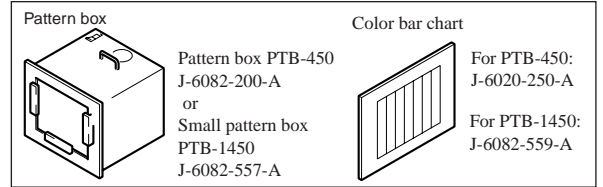

2. Adjust the distance so that the output waveform of Fig. a and the Fig. b can be obtain.

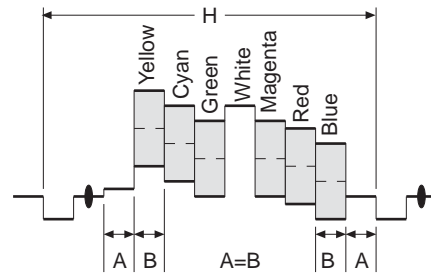

Fig. a (Video output terminal output waveform)

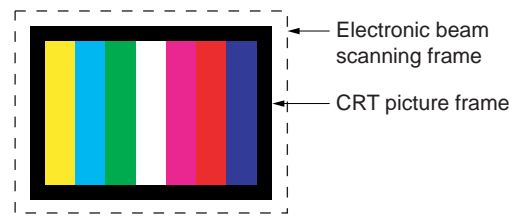

Fig.b (Picture on monitor TV)

When indicating parts by reference number, please include the board name.

The components identified by mark \triangle or dotted line with mark \triangle are critical for safety.
Replace only with part number specified.

Les composants identifiés par une marque \triangle sont critiques pour la sécurité.
Ne les remplacer que par une pièce portant le numéro spécifié.

CD-587 FLEXIBLE BOARD

CCD IMAGER

XX MARK:NO MOUNT

NO MARK:REC/PB MODE

R:REC MODE

P:PB MODE

Note: CD-587 flexible complete board and IC002 are not supplied, but there are included in CCD block assy.

Note: Voltage and Waveform of mounted IC002 on CD-587 flexible board can not be measured, because they are mounted by the side of the lens.

SY-134
(1/7)
CN601
(PAGE 4-9
of LEVEL3)

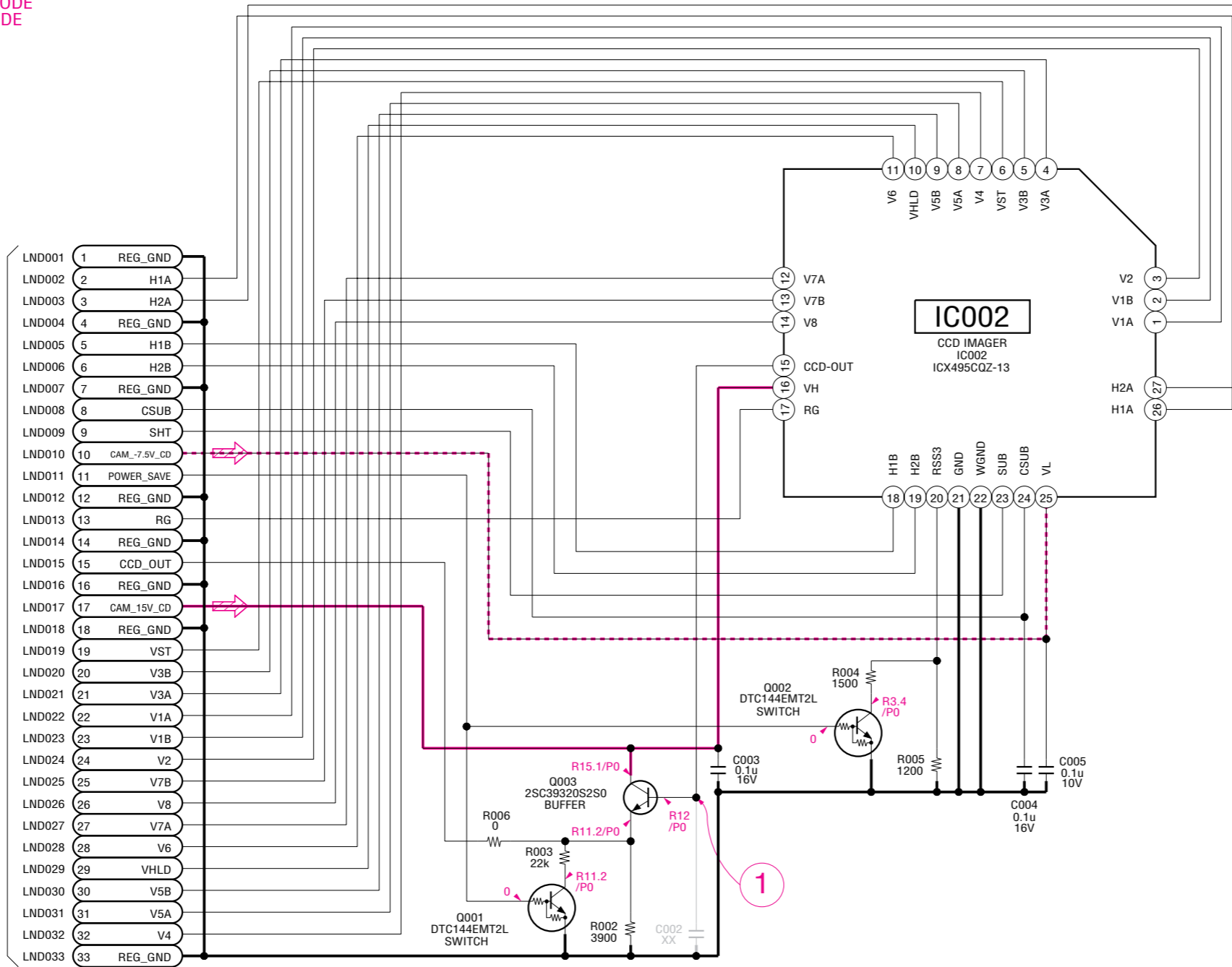

Schematic diagrams of the SY-134 board are not shown.
Pages from 4-9 to 4-22 are not shown.

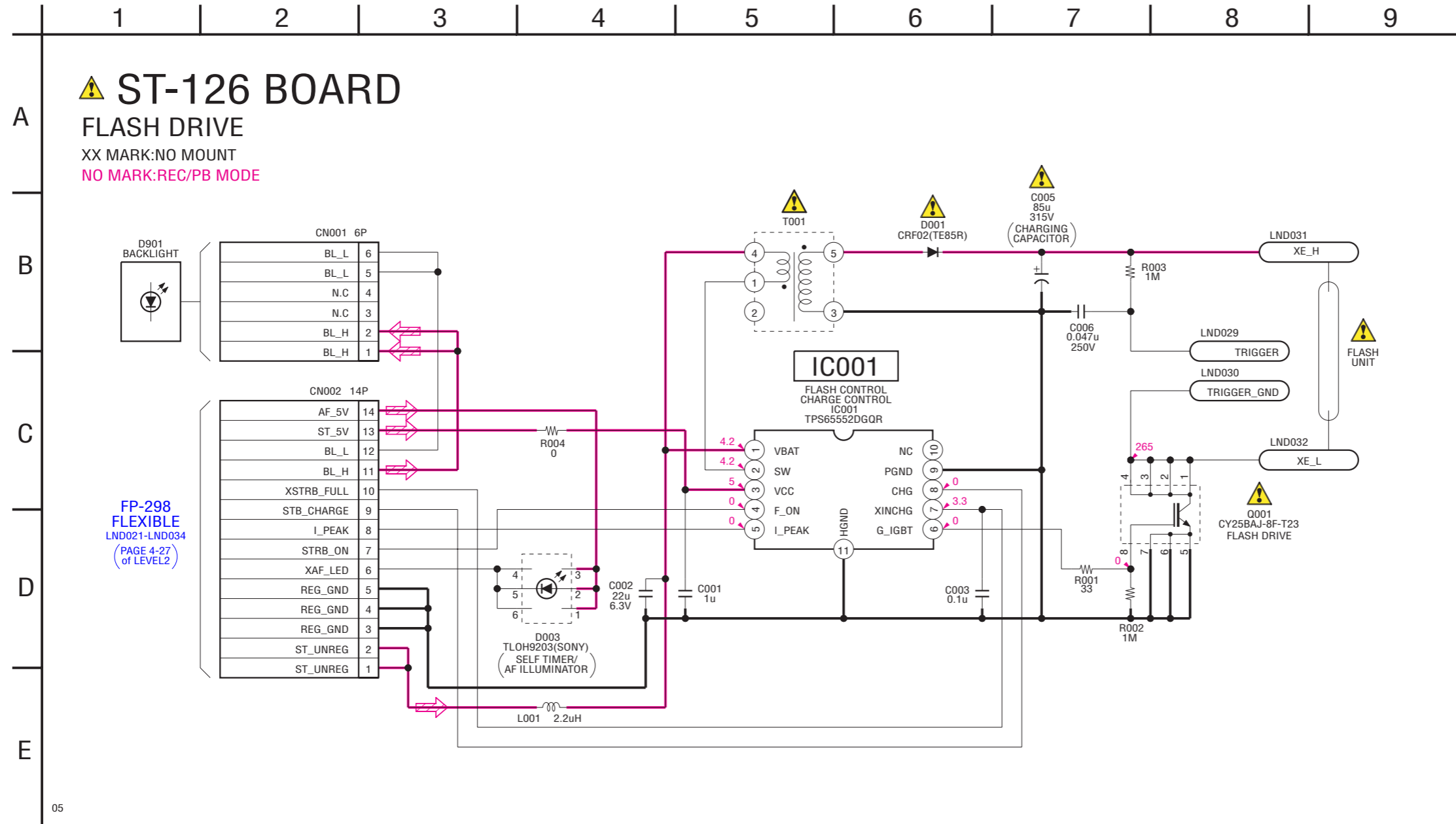

05

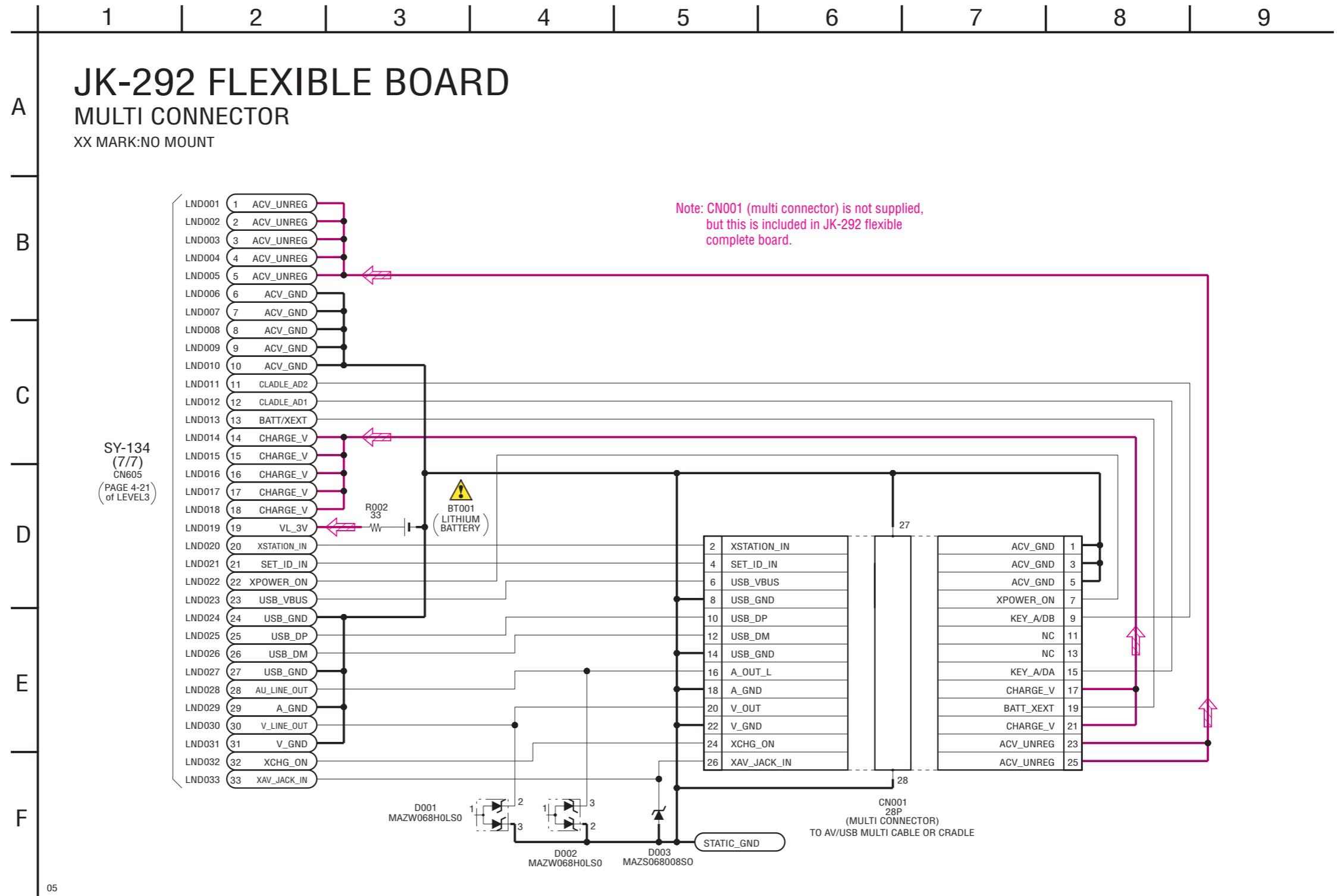

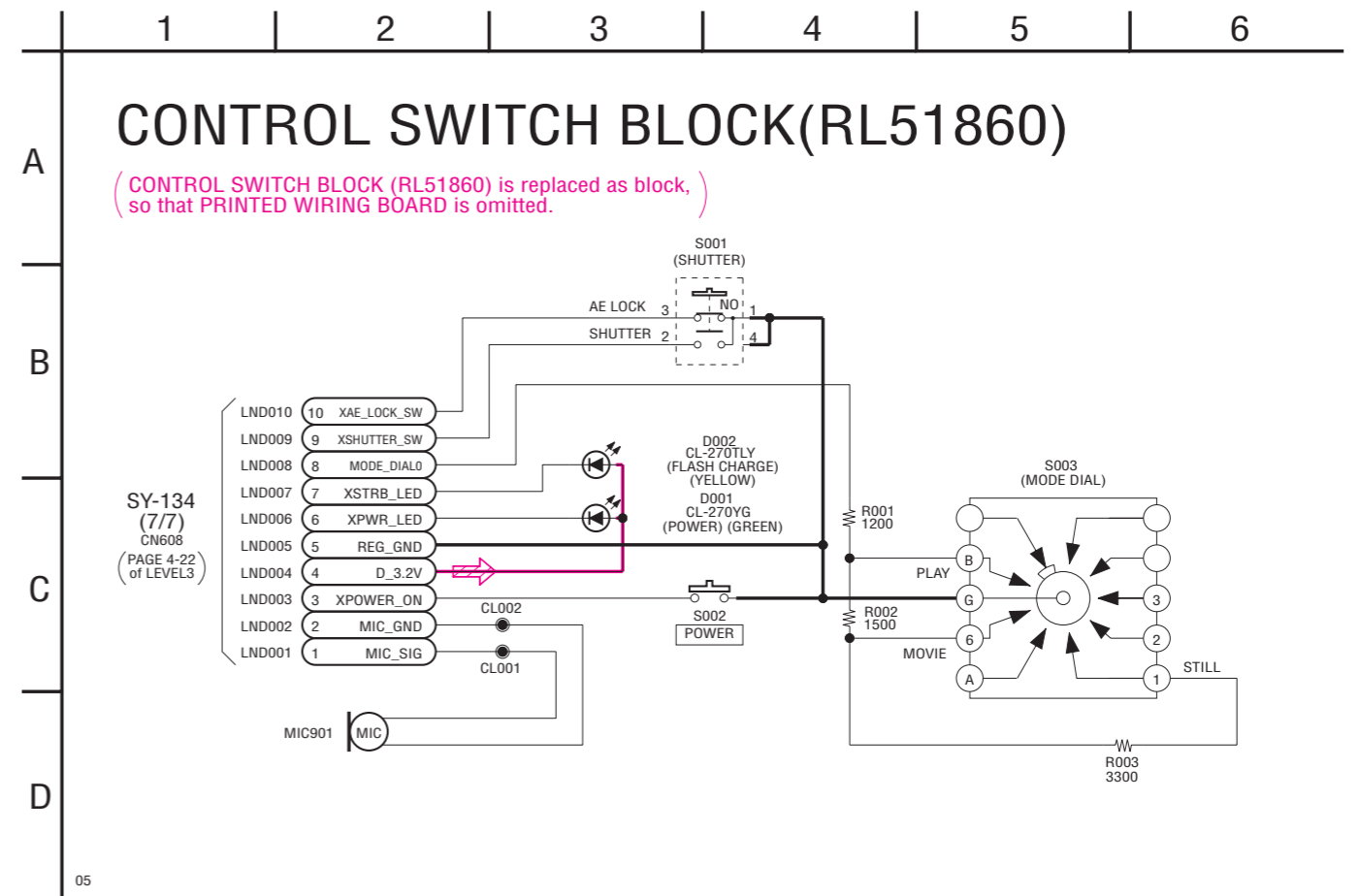
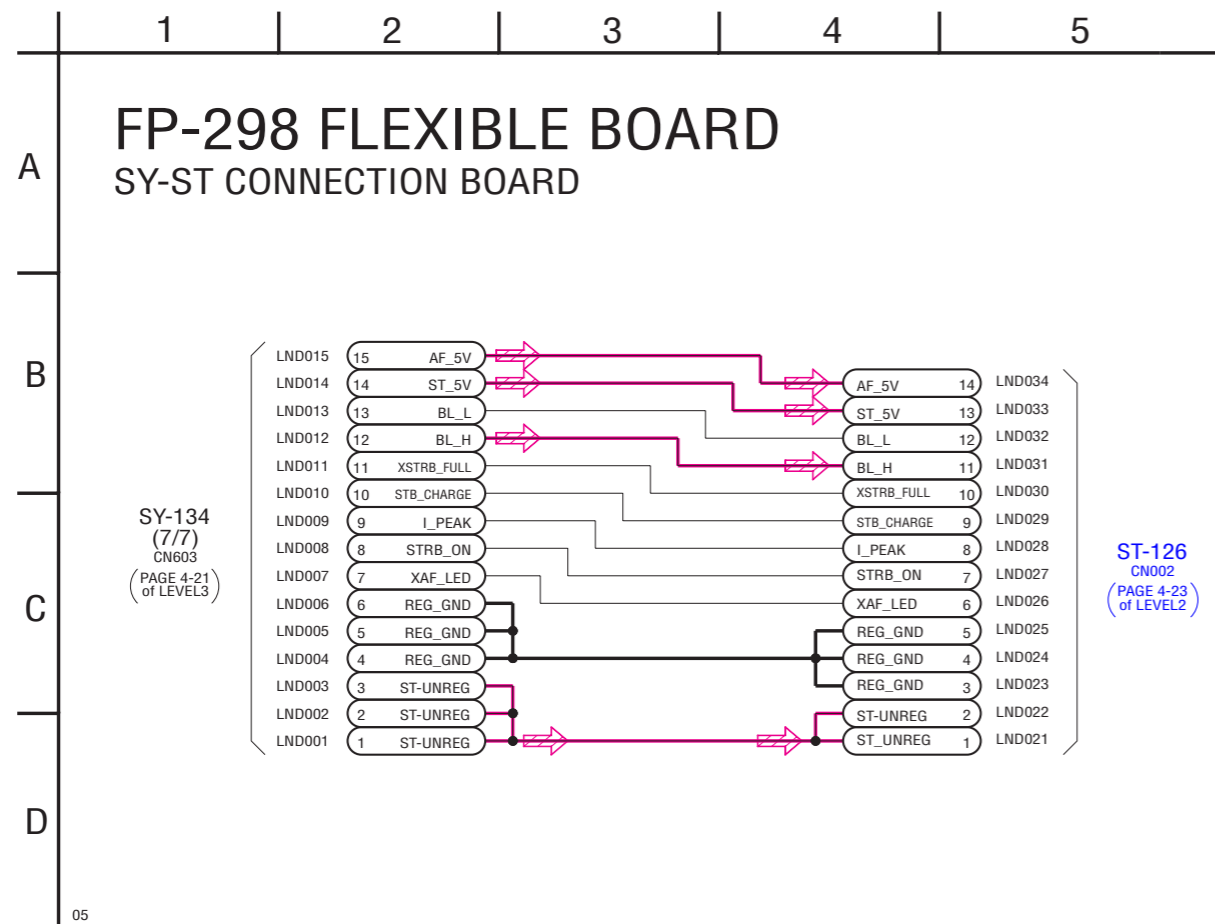
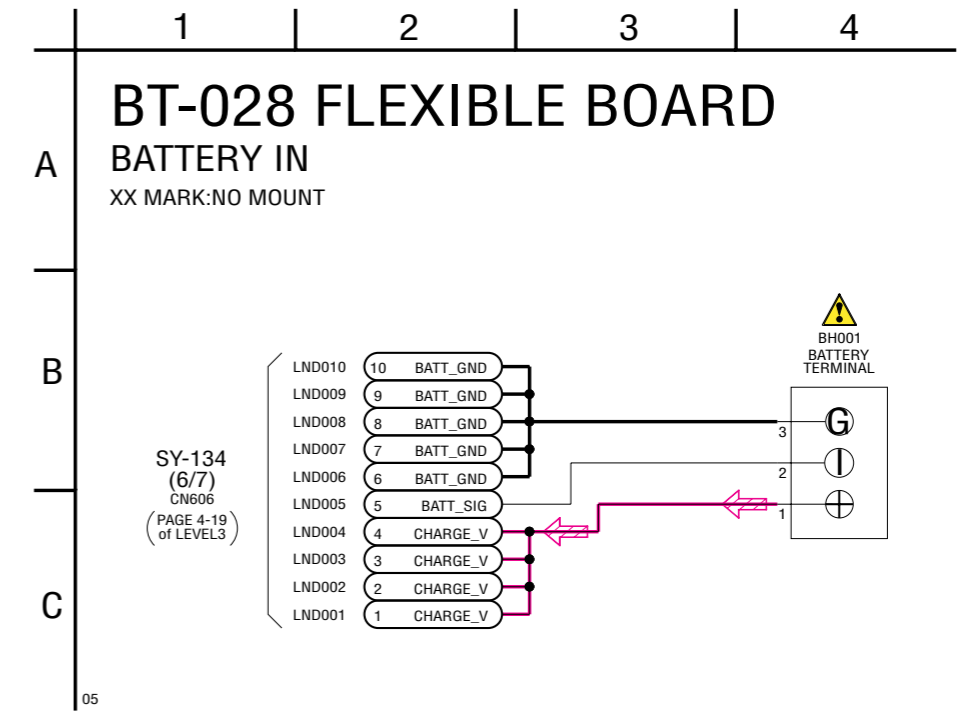
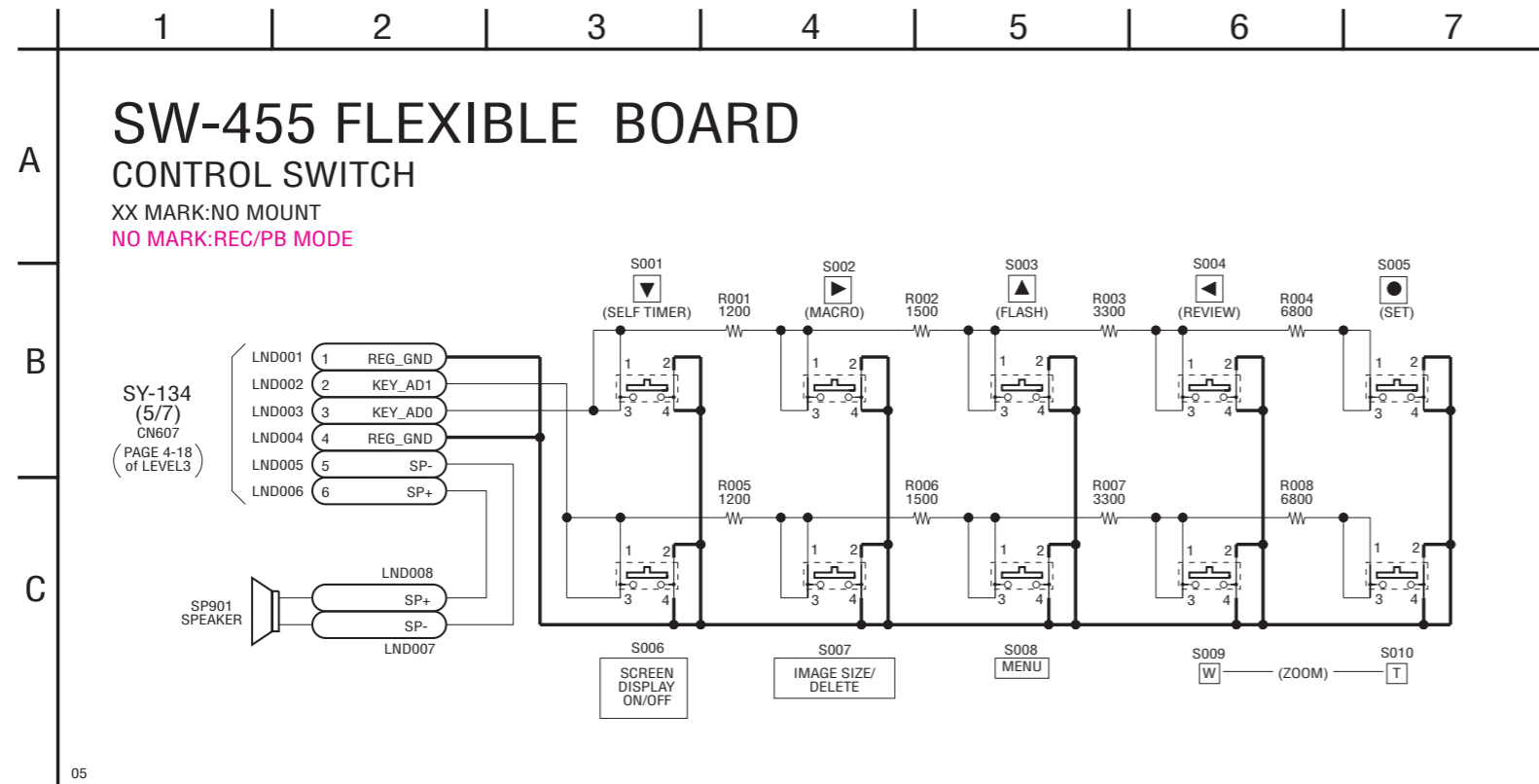

4-3. PRINTED WIRING BOARDS

Link

• CD-587 FLEXIBLE BOARD	• BT-028 FLEXIBLE BOARD
• ST-126 BOARD	• JK-292 FLEXIBLE BOARD
• SW-455 FLEXIBLE BOARD	• FP-298 FLEXIBLE BOARD
• COMMON NOTE FOR PRINTED WIRING BOARDS	
• WAVEFORMS	• MOUNTED PARTS LOCATION

4-3. PRINTED WIRING BOARDS

4-3. PRINTED WIRING BOARDS

THIS NOTE IS COMMON FOR PRINTED WIRING BOARDS

- : Uses unleaded solder.
- : Circuit board
- : Flexible board
- : Pattern from the side which enables seeing.
- : pattern of the rear side
(The other layers' patterns are not indicated)
- Through hole is omitted.
- Circled numbers refer to waveforms.
- There are a few cases that the part printed on diagram isn't mounted in this model.
- : panel designation

- Chip parts.

Transistor

Diode

CD-587 (2 layers)

 : Uses unleaded solder.

CD-587 FLEXIBLE BOARD

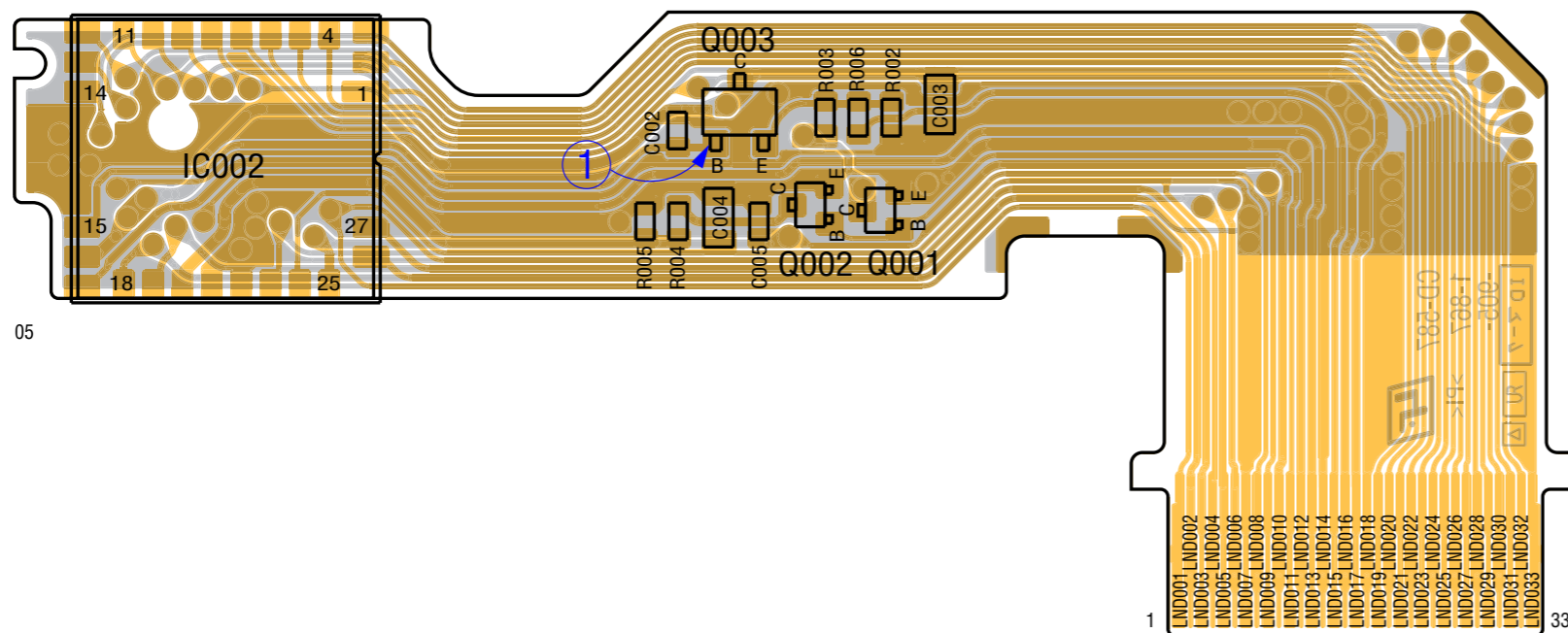

05

1-867-905-

11

Printed wiring boards of the SY-134 boards are not shown.
Pages from 4-35 to 4-38 are not shown.

ST-126 (4 layers)

 : Uses unleaded solder.

ST-126 BOARD (SIDE A)

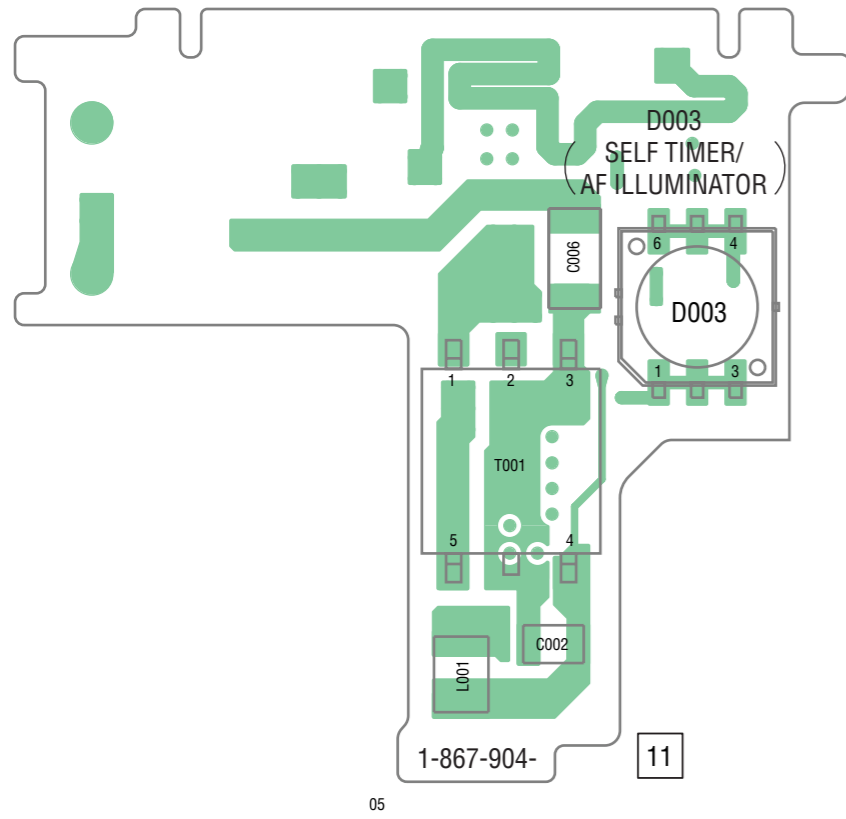

ST-126 BOARD (SIDE B)

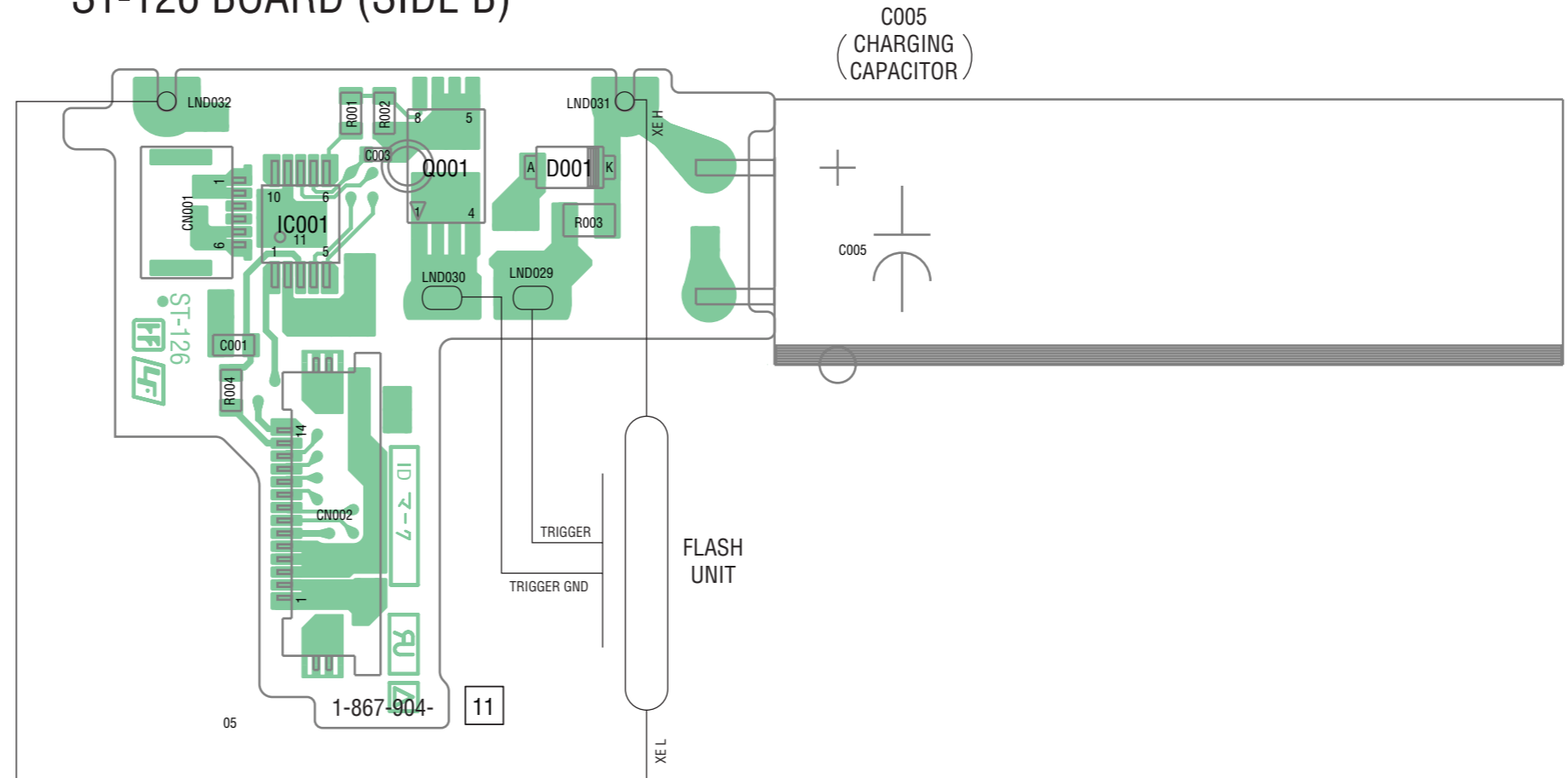

 : Uses unleaded solder.

SW-455 FLEXIBLE BOARD

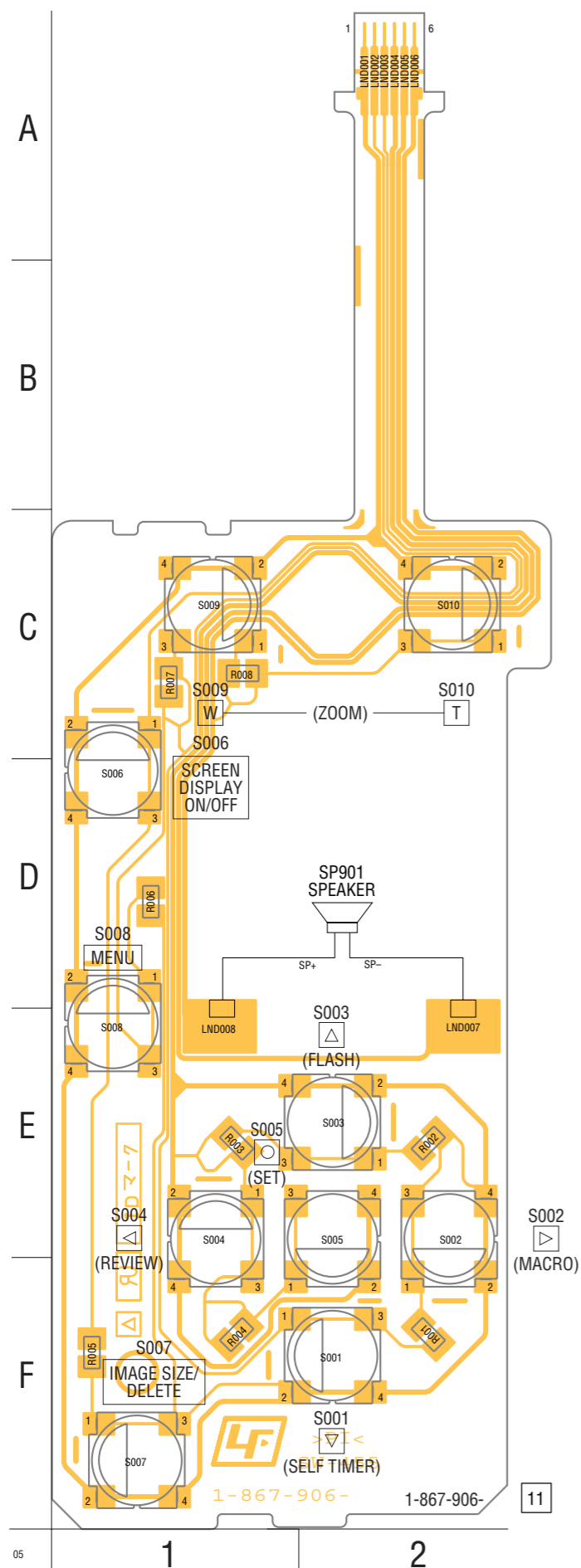

BT-028 FLEXIBLE BOARD

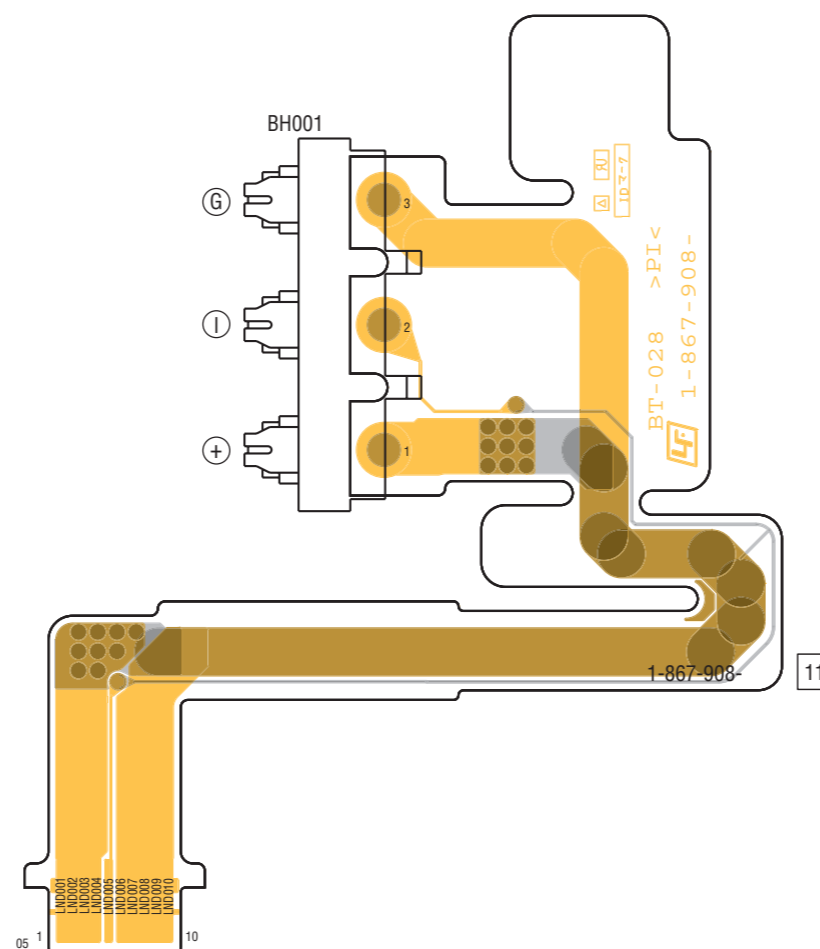

JK-292 FLEXIBLE BOARD

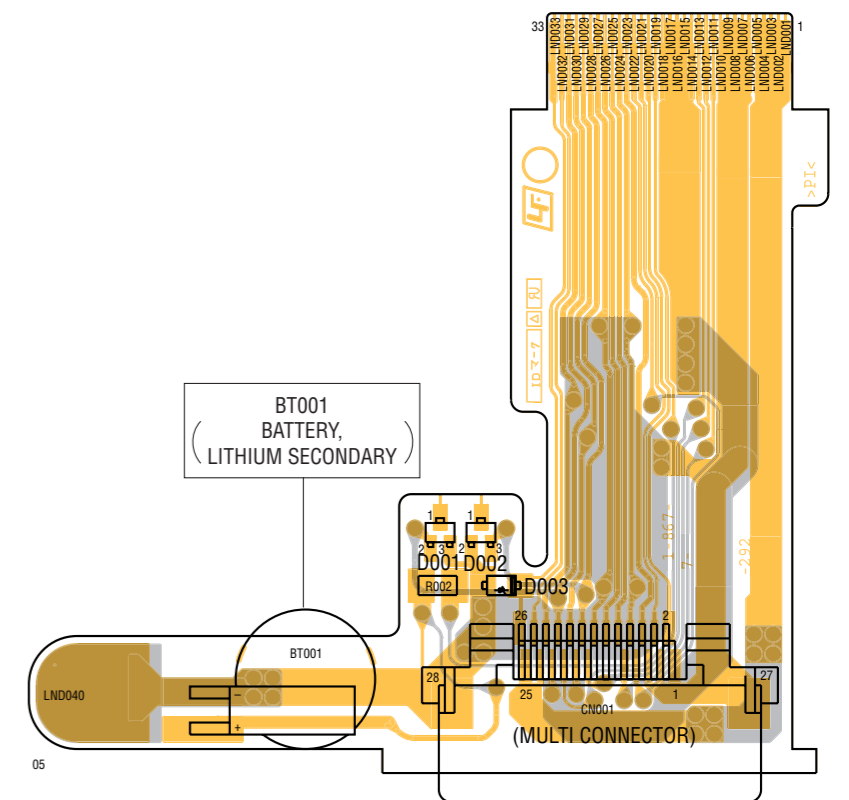

Note: CN001 (multi connector) is not supplied, but this is included in JK-292 flexible complete board.

FP-298 FLEXIBLE BOARD

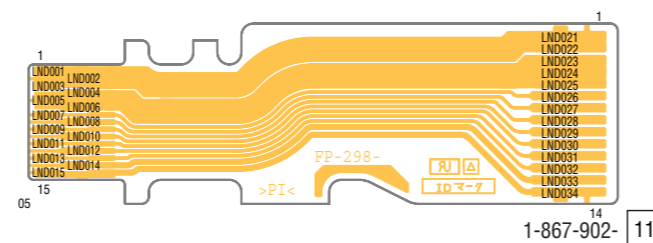

4-3. PRINTED WIRING BOARDS

4-4. WAVEFORMS

CD-587 FLEXIBLE BOARD

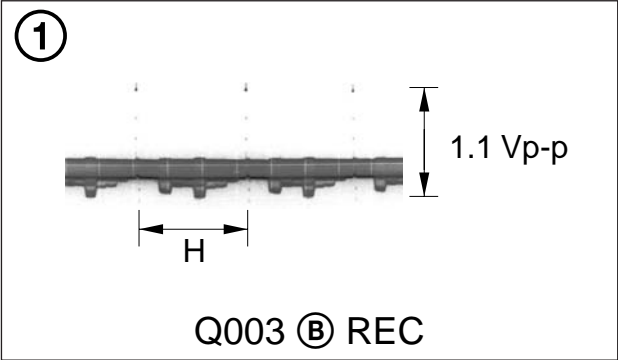

Waveforms of the SY-134 board are not shown.
Page 4-46 is not shown.

Mounted parts location of the SY-134 board is not shown.
Page 4-47 is not shown.

4-3. PRINTED WIRING BOARDS

4-5. MOUNTED PARTS LOCATION

no mark : side A

* mark : side B

SW-455 FLEXIBLE

R001	F-2
R002	E-2
R003	E-1
R004	F-1
R005	F-1
R006	D-1
R007	C-1
R008	C-1

S001	F-2
S002	E-2
S003	E-2
S004	E-1
S005	E-2
S006	D-1
S007	F-1
S008	E-1
S009	C-1
S010	C-2

5. REPAIR PARTS LIST

NOTE: Characters **A** to **Z** of the electrical parts list indicate location of exploded views in which the desired part is shown.

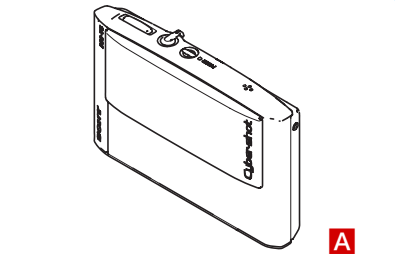
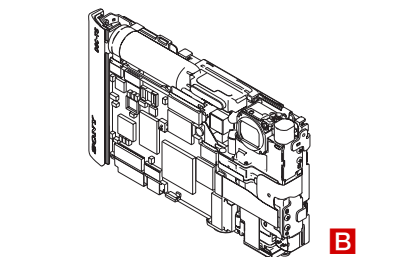
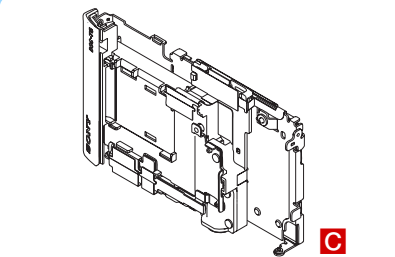
Link	EXPLODED VIEWS		
 <p data-bbox="328 786 507 815">CABINET SECTION</p>	 <p data-bbox="772 786 919 815">MAIN SECTION</p>	 <p data-bbox="1187 786 1375 815">BT BLOCK SECTION</p>	

Link	ELECTRICAL PARTS LIST		ACCESSORIES
<ul style="list-style-type: none"> BT-028 FLEXIBLE BOARD C 	<ul style="list-style-type: none"> JK-292 FLEXIBLE BOARD C 	<ul style="list-style-type: none"> SW-455 BOARD B 	
<ul style="list-style-type: none"> CD-587 FLEXIBLE BOARD B 	<ul style="list-style-type: none"> ST-126 BOARD B 		

5. REPAIR PARTS LIST

5. REPAIR PARTS LIST

NOTE:

- -XX, -X mean standardized parts, so they may have some differences from the original one.
- Items marked “*” are not stocked since they are seldom required for routine service. Some delay should be anticipated when ordering these items.
- The mechanical parts with no reference number in the exploded views are not supplied.
- Due to standardization, replacements in the parts list may be different from the parts specified in the diagrams or the components used on the set.
- CAPACITORS:
uF: μ F
- COILS
uH: μ H
- RESISTORS
All resistors are in ohms.
METAL: metal-film resistor
METAL OXIDE: Metal Oxide-film resistor
F: nonflammable
- SEMICONDUCTORS
In each case, u: μ , for example:
uA...: μ A... , uPA... , μ PA... ,
uPB... , μ PB... , μ PC... , μ PC... ,
uPD... , μ PD...
- Abbreviation
AR : Argentine model
AUS : Australian model
BR : Brazilian model
CH : Chinese model
CND : Canadian model
EE : East European model
HK : Hong Kong model
J : Japanese model
JE : Tourist model
KR : Korea model
NE : North European model

When indicating parts by reference number, please include the board name.

The components identified by mark \triangle or dotted line with mark \triangle are critical for safety. Replace only with part number specified.

Les composants identifiés par une marque \triangle sont critiques pour la sécurité. Ne les remplacer que par une pièce portant le numéro spécifié.

• Language that can be selected about SY-134 board

	Area	Japanese	English	French	German	Spanish	Italian	Portugal	Simplified Chinese	Traditional Chinese	Arabic	Dutch	Russian	Swedish	Korean	Norwegian	Danish	Finnish	Polish	Hungarian	Czech	Persian	Thai	
GP1	J	●																						
GP2	US CND AUS Vietnam		●	●		●	●		●	●														
GP3	AEP UK		●	●	●	●	●	●				●	●	●		●	●	●	●	●	●			
GP4	E AR BR TW JE HK CH KR		●			●		●	●	●	●				●								●	●

5. REPAIR PARTS LIST

5-1. EXPLODED VIEWS

5-1-1. CABINET SECTION

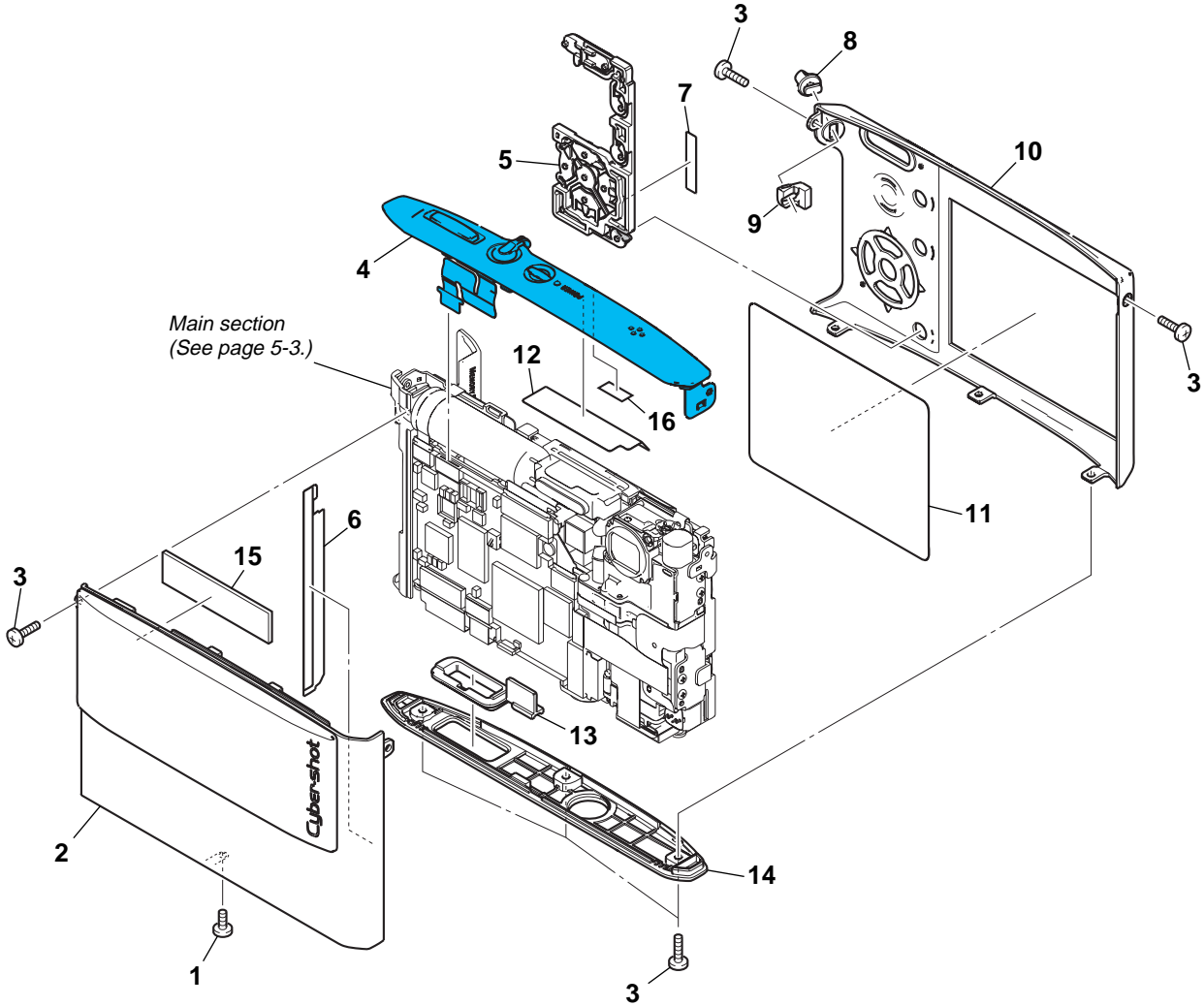

Ref. No.	Part No.	Description	Ref. No.	Part No.	Description
1	2-635-591-11	SCREW (M1.4), NEW TRUSTAR P2	9	2-637-501-01	HOLDER, STRAP
2	X-2067-184-1	CABINET (FRONT) ASSY (SILVER)	10	2-637-496-01	CABINET (REAR) (SILVER)
2	X-2067-185-1	CABINET (FRONT) ASSY (B) (BLACK)	10	2-637-496-11	CABINET (REAR) (BLACK)
2	X-2067-186-1	CABINET (FRONT) ASSY (R) (RED)	10	2-637-496-21	CABINET (REAR) (RED)
2	X-2067-187-1	CABINET (FRONT) ASSY (N) (GOLD)	10	2-637-496-31	CABINET (REAR) (GOLD)
3	2-635-591-01	SCREW (M1.4), NEW TRUSTAR P2	11	2-637-509-01	COVER, LCD
4	1-479-435-11	SWITCH BLOCK, CONTROL (RL51860)	* 12	2-637-495-01	SHEET, STROBOSCOPE INSULATING
5	2-637-497-01	BUTTON, FUNCTION	* 13	2-637-505-01	COVER, MULTI
* 6	2-637-511-01	SHEET, BLIND	14	2-637-504-01	BOTTOM, CABINET
7	2-637-498-01	SHEET (1), FUNCTION ADHESIVE	* 15	2-637-508-01	RADIATION SHEET, F
8	2-637-499-01	BRACKET, STRAP	* 16	2-653-866-01	SHEET (A), CABINET (UPPER)

5. REPAIR PARTS LIST

5-1-2. MAIN SECTION

ns: not supplied

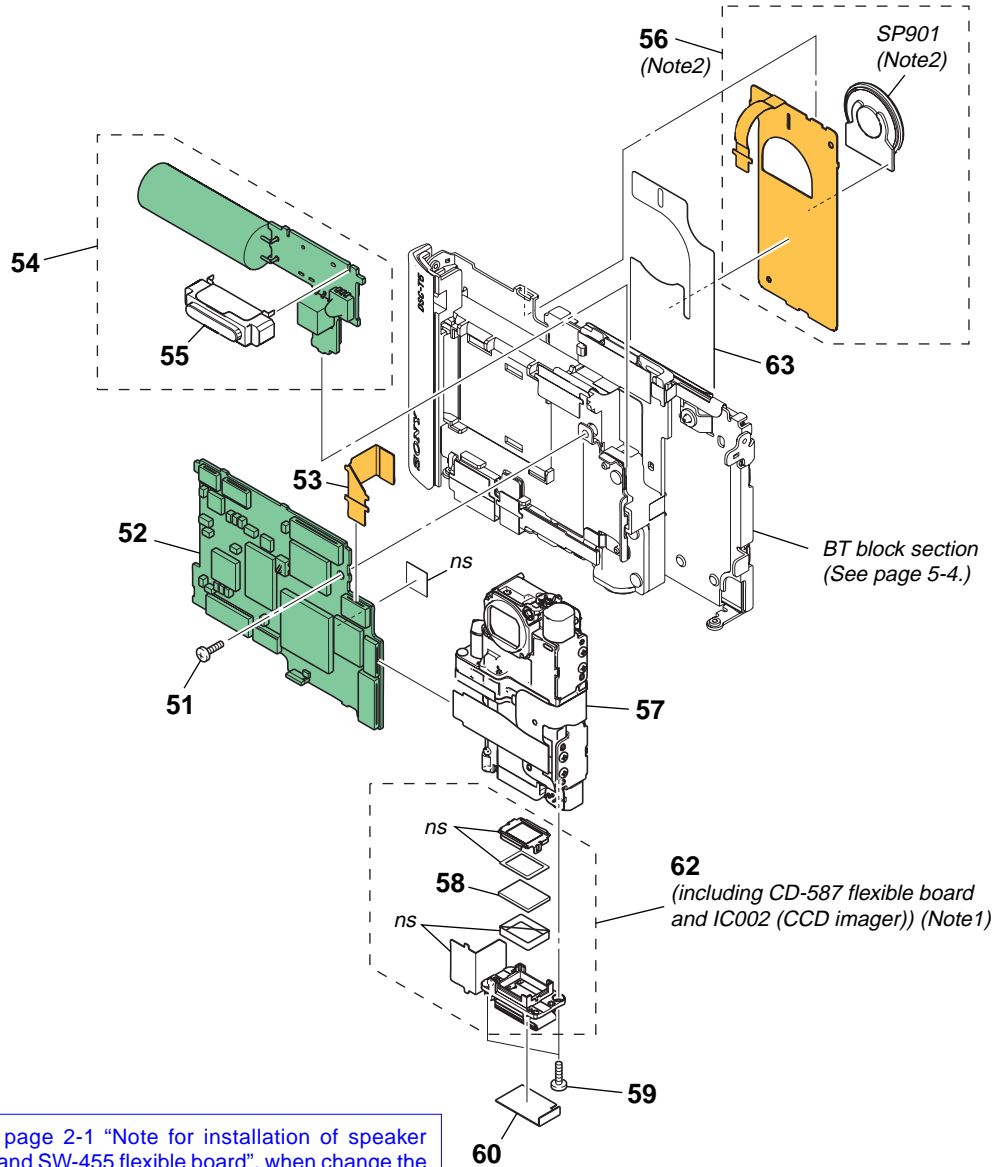

Note2: Refer to page 2-1 "Note for installation of speaker (SP901) and SW-455 flexible board", when change the speaker (SP901)

Note1: Be sure to read "Precautions for Replacement of Imager" on page 4-5 when changing the imager.

* Refer to the table of page 5-1 about language of SY-134 board.

• Refer to page 5-1 for mark △.

Ref. No.	Part No.	Description
51	3-078-889-21	SCREW (M1.7)
52	A-1142-659-A	SY-134 BOARD, COMPLETE (SERVICE) (GP1)
52	A-1146-566-A	SY-134 BOARD, COMPLETE (SERVICE) (GP2)
52	A-1146-567-A	SY-134 BOARD, COMPLETE (SERVICE) (GP3)
52	A-1146-568-A	SY-134 BOARD, COMPLETE (SERVICE) (GP4)
53	1-867-902-11	FP-298 FLEXIBLE BOARD
△54	A-1129-574-A	ST-126 BOARD, COMPLETE
△55	1-478-972-11	FLASH UNIT
56	A-1129-577-A	SW-455 FLEXIBLE BOARD, COMPLETE (Note2)

Ref. No.	Part No.	Description
57	A-1118-808-A	LSV-1040A (SERVICE)
58	1-788-249-21	OPTICALFILTER BLOCK (OFB-02-22)
59	3-086-156-11	SCREW B1.2
60	2-637-503-01	INSULATING SHEET, CCD
62	A-1129-513-A	CCD BLOCK ASSY (including CD-587 flexible board and IC002 (CCD imager)) (Note1)
* 63	2-637-510-01	SHEET, SP INSULATING
SP901	1-825-983-21	SPEAKER (1.62CM) (Note2)

5. REPAIR PARTS LIST

5-1-3. BT BLOCK SECTION

ns: not supplied

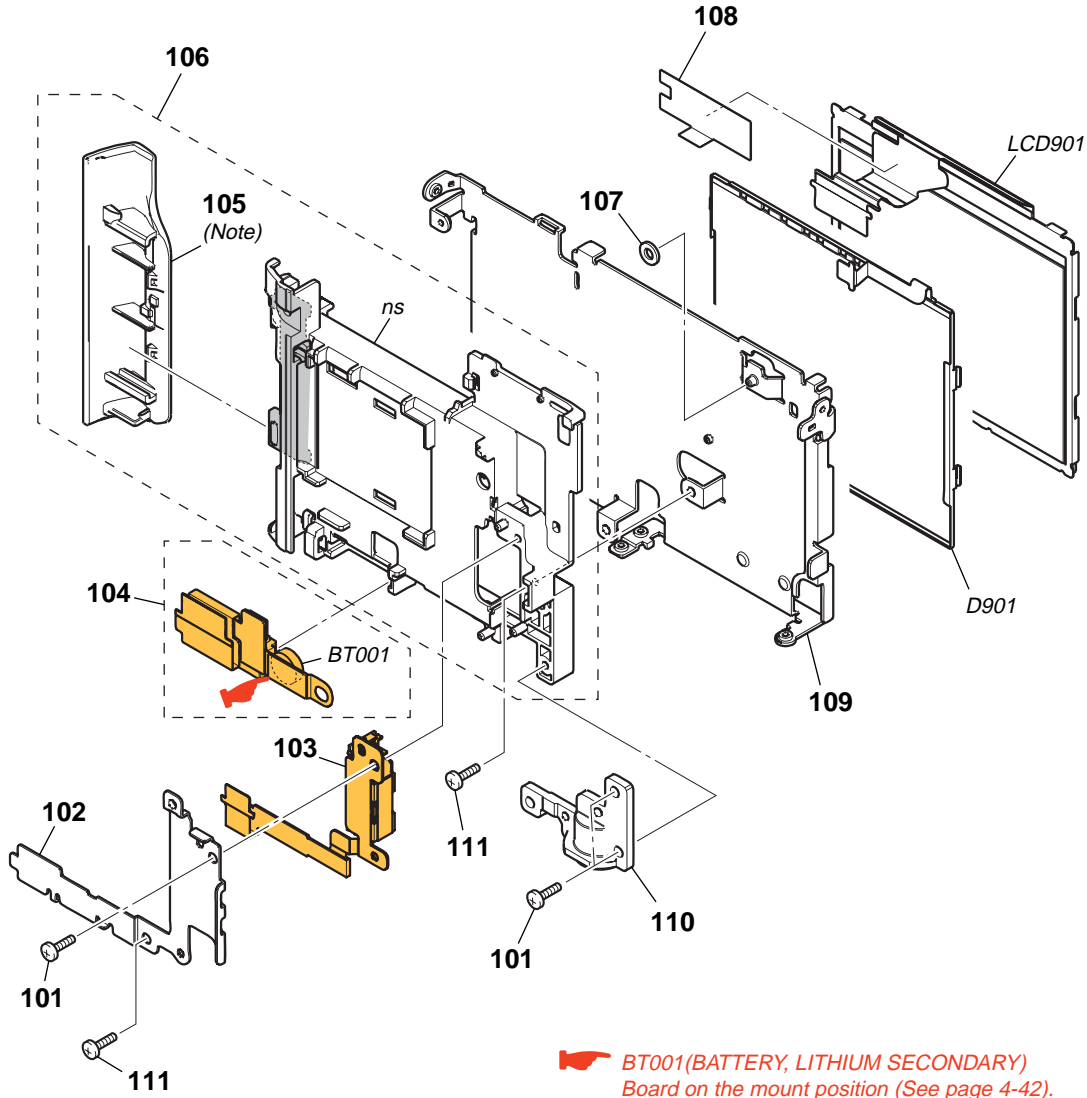

BT001 (BATTERY, LITHIUM SECONDARY)
Board on the mount position (See page 4-42).

Note: Be sure to read "2-1. DISASSEMBLY (How to disassemble BT lid)" on page 2-3.

CAUTION
Danger of explosion if battery is incorrectly replaced.
Replace only with the same or equivalent type.

- Refer to page 5-1 for mark △.

Ref. No.	Part No.	Description	Ref. No.	Part No.	Description
101	3-080-222-21	SCREW (M1.7), TAPPING, P2	* 108	2-637-494-01	SHEET, PANEL (FP) PROTECTION
* 102	2-637-492-01	FRAME, TERMINAL RETAINER	* 109	2-637-493-01	FRAME, MAIN
103	A-1129-578-A	BT-028 FLEXIBLE BOARD, COMPLETE	110	2-637-490-01	SCREW, TRIPOD
104	A-1129-576-A	JK-292 FLEXIBLE BOARD, COMPLETE (including CN001 (multi connector))	111	3-078-889-21	SCREW (M1.7)
105	2-637-480-01	LID, BT (Note)	△ BT001	1-756-566-11	BATTERY, LITHIUM SECONDARY
106	X-2067-188-1	HOLDER ASSY, BT	D901	1-479-381-11	BLOCK, LIGHT GUIDE PLATE (2.5)
* 107	2-637-491-01	CUSHION, LENS	LCD901	A-1146-639-A	SERVICE, LCD BLOCK ASSY (SERVICE)

5-2. ELECTRICAL PARTS LIST

Ref. No.	Part No.	Description
	A-1129-578-A	BT-028 FLEXIBLE BOARD, COMPLETE *****
		< BATTERY TERMINAL >
△ BH001	1-780-196-11	TERMINAL BOARD, BATTERY
	A-1129-513-A	CCD BLOCK ASSY (Not supplied) CD-587 FLEXIBLE BOARD, COMPLETE ***** (CCD block assy is including CD-587 flexible board and IC002 (CCD imager))
		< CAPACITOR >
C003	1-107-826-11	CERAMIC CHIP 0.1uF 10% 16V
C004	1-107-826-11	CERAMIC CHIP 0.1uF 10% 16V
C005	1-125-777-11	CERAMIC CHIP 0.1uF 10% 10V
		< IC >
IC002	(Not supplied)	ICX495CQZ-13 (Note)
		< TRANSISTOR >
Q001	6-550-119-01	TRANSISTOR DTC144EMT2L
Q002	6-550-119-01	TRANSISTOR DTC144EMT2L
Q003	6-550-885-01	TRANSISTOR 2SC39320S2S0
		< RESISTOR >
R002	1-218-960-11	RES-CHIP 3.9K 5% 1/16W
R003	1-218-969-11	RES-CHIP 22K 5% 1/16W
R004	1-218-955-11	RES-CHIP 1.5K 5% 1/16W
R005	1-218-954-11	RES-CHIP 1.2K 5% 1/16W
R006	1-218-990-81	SHORT CHIP 0
	A-1129-576-A	JK-292 FLEXIBLE BOARD, COMPLETE ***** (This flexible complete board is including CN001 (multi connector))
		< BATTERY >
△ BT001	1-756-566-11	BATTERY, LITHIUM SECONDARY
		< CONNECTOR >
CN001	(Not supplied)	CONNECTOR, MULTIPLE (SOCKET)
		< DIODE >
D001	6-500-776-01	DIODE MAZW068H0LS0
D002	6-500-776-01	DIODE MAZW068H0LS0
D003	8-719-056-54	DIODE MAZS068008S0
		< RESISTOR >
R002	1-216-803-11	METAL CHIP 33 5% 1/10W
	A-1129-574-A	ST-126 BOARD, COMPLETE *****
△	1-478-972-11	FLASH UNIT

Note: Be sure to read "Precautions for Replacement of Imager" on page 4-5 when changing the imager.

Ref. No.	Part No.	Description
		< CAPACITOR >
C001	1-165-908-11	CERAMIC CHIP 1uF 10% 10V
C002	1-100-611-91	CERAMIC CHIP 22uF 20% 6.3V
C003	1-125-777-11	CERAMIC CHIP 0.1uF 10% 10V
△ C005	1-112-675-11	CAP, ELECT 85uF 315V
C006	1-100-758-11	CERAMIC CHIP 0.047uF 10% 250V
		< CONNECTOR >
* CN001	1-816-654-51	FFC/FPC CONNECTOR (LIF) 6P
* CN002	1-819-551-51	CONNECTOR, FFC/FPC (ZIF) 14P
		< DIODE >
△ D001	6-501-096-01	DIODE CRF02 (TE85R)
* D003	6-501-313-01	DIODE TLOH9203 (SONY) (SELF TIMER/AF ILLUMINATOR)
		< IC >
IC001	6-707-554-01	IC TPS65552DGQR
		< COIL >
* L001	1-400-820-11	INDUCTOR 2.2uH
		< TRANSISTOR >
△ Q001	6-550-656-01	TRANSISTOR CY25BAJ-8F-T23
		< RESISTOR >
R001	1-216-803-11	METAL CHIP 33 5% 1/10W
R002	1-216-857-11	METAL CHIP 1M 5% 1/10W
R003	1-216-121-11	RES-CHIP 1M 5% 1/10W
R004	1-216-864-11	SHORT CHIP 0
		< TRANSFORMER >
△ T001	1-443-648-21	DC-DC CONVERTER TRANSFORMER
	A-1129-577-A	SW-455 FLEXIBLE BOARD, COMPLETE *****
SP901	1-825-983-21	LOUDSPEAKER (1.62CM)
		< RESISTOR >
R001	1-216-822-11	METAL CHIP 1.2K 5% 1/10W
R002	1-216-823-11	METAL CHIP 1.5K 5% 1/10W
R003	1-216-827-11	METAL CHIP 3.3K 5% 1/10W
R004	1-218-867-11	METAL CHIP 6.8K 0.5% 1/10W
R005	1-216-822-11	METAL CHIP 1.2K 5% 1/10W
R006	1-216-823-11	METAL CHIP 1.5K 5% 1/10W
R007	1-216-827-11	METAL CHIP 3.3K 5% 1/10W
R008	1-218-867-11	METAL CHIP 6.8K 0.5% 1/10W
		< SWITCH >
S001	1-786-157-11	SWITCH, TACTILE (▽ (SELF TIMER))
S002	1-786-157-11	SWITCH, TACTILE (▷ (MACRO))
S003	1-786-157-11	SWITCH, TACTILE (△ (FLASH))
S004	1-786-157-11	SWITCH, TACTILE (◁ (REVIEW))

• Refer to page 5-1 for mark △.

SW-455

<u>Ref. No.</u>	<u>Part No.</u>	<u>Description</u>
S005	1-786-157-11	SWITCH, TACTILE (O (SET))
S006	1-786-157-11	SWITCH, TACTILE (SCREEN DISPLAY ON/OFF)
S007	1-786-157-11	SWITCH, TACTILE (IMAGE SIZE/DELETE)
S008	1-786-157-11	SWITCH, TACTILE (MENU)
S009	1-786-157-11	SWITCH, TACTILE (W (ZOOM))
S010	1-786-157-11	SWITCH, TACTILE (T (ZOOM))

Electrical parts list of the SY-134 board is not shown.
Pages 5-7 to 5-10 are not shown.

Checking supplied accessories.

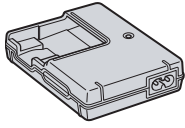

Battery charger BC-CS3 (1)
△ 1-479-140-11 (J)
△ 1-479-140-21 (US, CND)
△ 1-479-140-31 (EXCEPT US, CND, J)

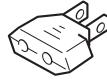

Conversion adaptor (1)
1-569-008-21 (E)



Conversion adaptor (1)
1-573-856-12 (JE)



Power cord (mains lead) (1)
△ 1-776-985-11 (KR)
△ 1-782-476-51 (CH)
△ 1-783-374-11 (UK, HK)
△ 1-790-732-71 (JE)
△ 1-823-946-12 (AEP, E)
△ 1-827-945-12 (AUS)

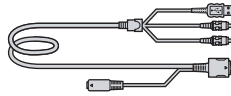

USB, A/V, DC IN cable
for multi-use terminal (1)
1-830-848-11

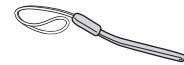

Wrist strap (1)
2-050-981-01

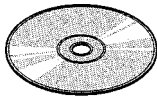

CD-ROM
(Cyber-shot application software)
2-650-869-01

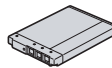

Rechargeable battery pack
NP-FT1 (1)
(not supplied)

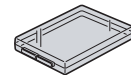

Battery case (1)
(not supplied)

• Refer to page 5-1 for mark △.

Checking supplied accessories.

Other accessories

2-635-477-01 INSTRUCTION (READ THIS FIRST) (JAPANESE) (J)	2-635-482-21 INSTRUCTION (USER'S GUIDE) (FRENCH, ITALIAN) (CND, AEP)
2-635-477-11 INSTRUCTION (READ THIS FIRST) (ENGLISH) (AEP, UK, E, HK, AUS, JE)	2-635-482-31 INSTRUCTION (USER'S GUIDE) (SPANISH, PORTUGUESE) (AEP, E, JE)
2-635-477-21 INSTRUCTION (READ THIS FIRST) (FRENCH, ITALIAN) (AEP)	2-635-482-41 INSTRUCTION (USER'S GUIDE) (GERMAN, DUTCH) (AEP)
2-635-477-31 INSTRUCTION (READ THIS FIRST) (SPANISH, PORTUGUESE) (AEP, E, JE)	2-635-482-51 INSTRUCTION (USER'S GUIDE) (TRADITIONAL CHINESE, SIMPLIFIED CHINESE) (E, HK, CH, JE)
2-635-477-41 INSTRUCTION (READ THIS FIRST) (GERMAN, DUTCH) (AEP)	2-635-482-61 INSTRUCTION (USER'S GUIDE) (RUSSIAN) (AEP)
2-635-477-51 INSTRUCTION (READ THIS FIRST) (TRADITIONAL CHINESE, SIMPLIFIED CHINESE) (E, HK, CH, JE)	2-635-482-71 INSTRUCTION (USER'S GUIDE) (ARABIC, PERSIAN) (E)
2-635-477-61 INSTRUCTION (READ THIS FIRST) (RUSSIAN) (AEP)	2-635-482-81 INSTRUCTION (USER'S GUIDE) (KOREAN) (KR, JE)
2-635-477-71 INSTRUCTION (READ THIS FIRST) (ARABIC, PERSIAN) (E)	2-635-482-91 INSTRUCTION (USER'S GUIDE) (POLISH, CZECH) (AEP)
2-635-477-81 INSTRUCTION (READ THIS FIRST) (KOREAN) (KR, JE)	2-635-483-11 INSTRUCTION (USER'S GUIDE) (HUNGARIAN, SLOVAK) (AEP)
2-635-477-91 INSTRUCTION (READ THIS FIRST) (CZECH, POLISH) (AEP)	2-635-483-21 INSTRUCTION (USER'S GUIDE) (SWEDISH, FINNISH) (AEP)
2-635-481-11 INSTRUCTION (READ THIS FIRST) (HUNGARIAN, SLOVAK) (AEP)	2-635-483-31 INSTRUCTION (USER'S GUIDE) (NORWEGIAN, DANISH) (AEP)
2-635-481-21 INSTRUCTION (READ THIS FIRST) (SWEDISH, FINNISH) (AEP)	2-638-045-11 INSTRUCTION (READ THIS FIRST) (ENGLISH) (US)
2-635-481-31 INSTRUCTION (READ THIS FIRST) (NORWEGIAN, DANISH) (AEP)	2-638-045-21 INSTRUCTION (READ THIS FIRST) (FRENCH) (CND)
2-635-482-01 INSTRUCTION (USER'S GUIDE) (JAPANESE) (J)	
2-635-482-11 INSTRUCTION (USER'S GUIDE) (ENGLISH) (EXCEPT KR, J)	

DSC-T5

SONY®

LEVEL 2

SERVICE MANUAL

Ver 1.1 2005.09

US Model
Canadian Model
AEP Model
UK Model
E Model
Australian Model
Hong Kong Model
Chinese Model
Korea Model
Brazilian Model
Japanese Model
Tourist Model

SUPPLEMENT-1



File this supplement with the service manual.
(PV05-051)

- Addition of Brazilian Model

The differences with other area models are only accessories.

Checking supplied accessories.

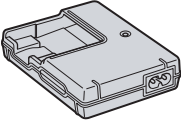
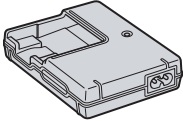
: Points add portion.

Page	Former	New
5-11	 Battery charger BC-CS3 (1) △ 1-479-140-11 (J) △ 1-479-140-21 (US, CND) △ 1-479-140-31 (EXCEPT US, CND, J)	 Battery charger BC-CS3 (1) △ 1-479-140-11 (J) △ 1-479-140-21 (US, CND) △ 1-479-140-31 (EXCEPT US, CND, BR, J) 
5-12	2-635-482-11 INSTRUCTION (USER'S GUIDE) (ENGLISH) (EXCEPT KR, J)	2-635-482-11 INSTRUCTION (USER'S GUIDE) (ENGLISH) (EXCEPT KR, BR, J) 

[Description of main button functions on toolbar of the Adobe Acrobat Reader Ver5.0 (for Windows)]



Toolbar



Printing a text

1. Click the Print button .
2. Specify a printer, print range, number of copies, and other options, and then click [OK].

Application of printing:

To set a range to be printed within a page, select the graphic selection tool  and drag on the page to enclose a range to be printed, and then click the Print button.

Reversing the screens displayed once

- To reverse the previous screens (operation) one by one, click the .
- To advance the reversed screens (operation) one by one, click the .

Application to the Service Manual:

This function allows you to go and back between circuit diagram and printed circuit board diagram, and accordingly it will be convenient for the voltage check.

Finding a text

1. Click the Find button .
2. Enter a character string to be found into a text box, and click the [Find]. (Specify the find options as necessary)

Application to the Service Manual:

To execute "find" from current page toward the previous pages, select the check box "Find Backward" and then click the "Find".

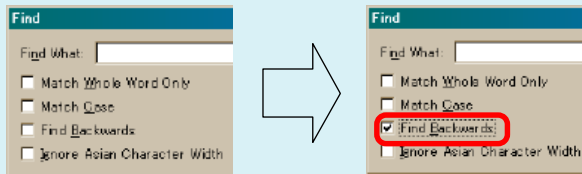





3. Open the find dialog box again, and click the [Find Again] and you can find the matched character strings displayed next. (Character strings entered previously are displayed as they are in the text box.)

Application to the Service Manual:

The parts on the drawing pages (block diagrams, circuit diagrams, printed circuit boards) and parts list pages in a text can be found using this find function. For example, find a Ref. No. of IC on the block diagram, and click the [Find Again] continuously, so that you can move to the Ref. No. of IC on the circuit diagram or printed circuit board diagram successively.

Note: The find function may not be applied to the Service Manual depending on the date of issue.

Moving with link

1. Select either palm tool , zoom tool , text selection tool , or graphic selection tool .
2. Place the pointer in the position in a text where the link exists (such as a button on cover and the table of contents page, or blue characters on the removal flowchart page or drawing page), and the pointer will change to the forefinger form .
3. Then, click the link. (You will go to the link destination.)

Moving with bookmark:

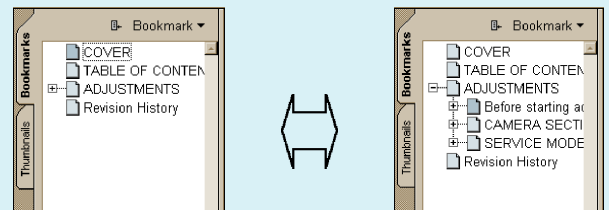

Click an item (text) on the bookmark pallet. and you can move to the link destination. Also, clicking  can display the hidden items.

(To go back to original state, click )



Zooming or rotating the screen display

"Zoom in/out"

- Click the triangle button in the zoom control box to select the display magnification. Or, you may click  or  for zooming in or out.

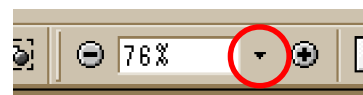





"Rotate"

- Click rotate tool , and the page then rotates 90 degrees each.

Application to the Service Manual:

The printed circuit board diagram you see now can be changed to the same direction as the set.

Switching a page

- To move to the first page, click the .
- To move to the last page, click the .
- To move to the previous page, click the .
- To move to the next page, click the .

